

**RESILIENT
WEDGE VALVES**

CLOW VALVE COMPANY

**CLOW AWWA Resilient Wedge Gate Valves
Meet or Exceed the Requirements of
AWWA Standard C515**

Size Range	Water Working Pressure psi	Bubble Tight Test psi	Hydrostatic Shell Test psi
AWWA 4"-48"	250	250	500
ULFM 4"-16"	200	200	400

Available in either non-rising stem, outside screw & yoke.

Available End Connections & Size Range		Figure No.
FLG End (NRS)	4"-48"	F-6102
M.J.	4"-48"(except 2 1/2")	F-6100
FLG & M.J.	4"-48"	F-6106
Push-on for PVC (SDR)	4"-12"	F-6110
FLG End (OS & Y)	4"-24"	F-6136
M.J. for Tapping	4"-24"	F-6114
Tyton for D.I. & C900 PVC	4"-12" & 16"	F-6112
M.J. Cutting-in	4"-12"	F-6111
Tyton for D.I. X FLG	4"-12"	F-6113

Accessories (Illustrated in the Gate Valve Section)

Indicator Posts	2" Sq. Operating Nuts
Enclosed Gearing (14"-24")	Handwheels
"T" Handles	Extension Stems
Stem Guides	Floor Boxes
Electric Motor Actuators	Chain Wheels
Floorstands (non-rising stem)	

NOTE:

It is recommended that valves be installed with stems vertical when used in raw sewage or sludge applications or in water with excessive sediment.

MODEL 2638 AWWA C515 REDUCED WALL DUCTILE IRON

Complies with applicable requirements of AWWA C515

14"-20" R/W VALVE
BEVEL GEAR MATERIAL LIST
CLOW VALVE COMPANY

MODEL 2638

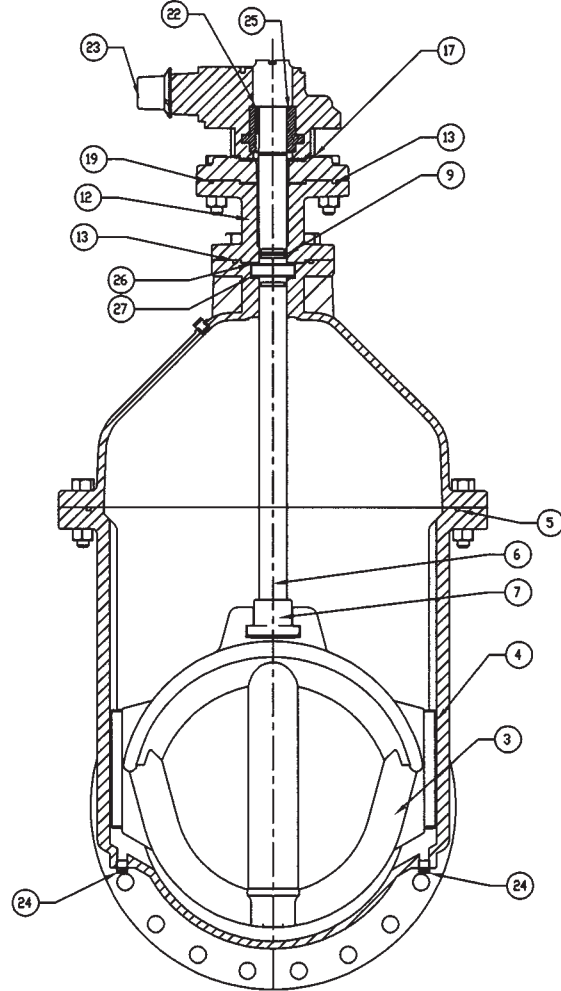
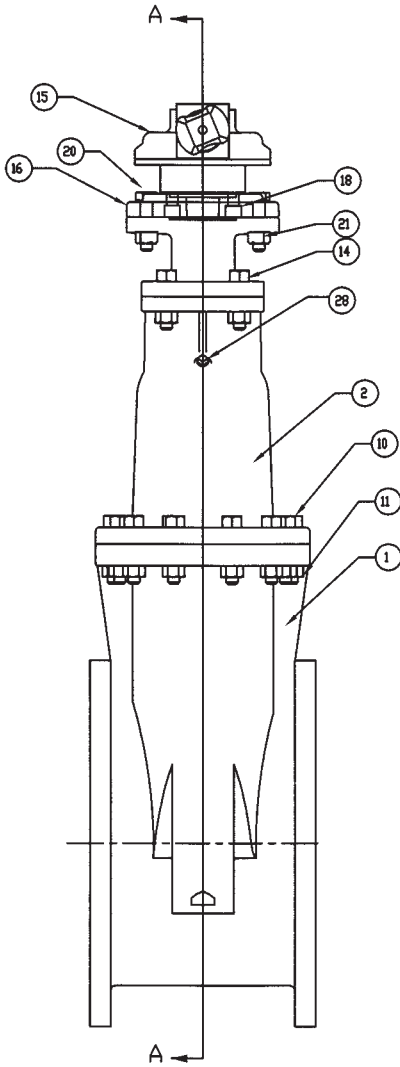

ITEM NO.	DESCRIPTION	MATERIAL
1	Body	Ductile Iron
2	Cover	Ductile Iron
3	Wedge	Ductile Iron/Rubber
4	Wedge Cap (18"-20" only)	Delrin
5	Oring	Rubber
6	Stem	Copper Alloy
7	Stem Nut	Copper Alloy
9	Oring	Rubber
10	Hex Head Bolt	Stainless Steel
11	Hex Nut	Stainless Steel
12	Extension	Ductile Iron
13	Oring	Rubber
14	Hex Head Bolt	Stainless Steel
15	Actuator - 3:1 (18"-20") 2:1 (14-16")	
16	Adaptor Plate	Ductile Iron
17	Actuator Gasket	Rubber
18	Socket Head Bolt	Alloy Steel
19	Oring	Rubber
20	Hex Bolt	Stainless Steel
21	Hex Nut	Stainless Steel
22	Key	Steel
23	Op Nut	Ductile Iron
24	Pipe Plug - 3/4 NPT with square hd	Stainless Steel
25	Drive Sleeve	Steel
26	Thrust Bearing	Delrin
27	Thrust Bearing (18"-20" only)	Delrin
28	Pipe Plug - 1/2 NPT with square hd	Stainless Steel

Complies with applicable requirements of AWWA C515

14"-20" R/W VALVE
SPUR GEAR MATERIAL LIST
CLOW VALVE COMPANY

MODEL 2638

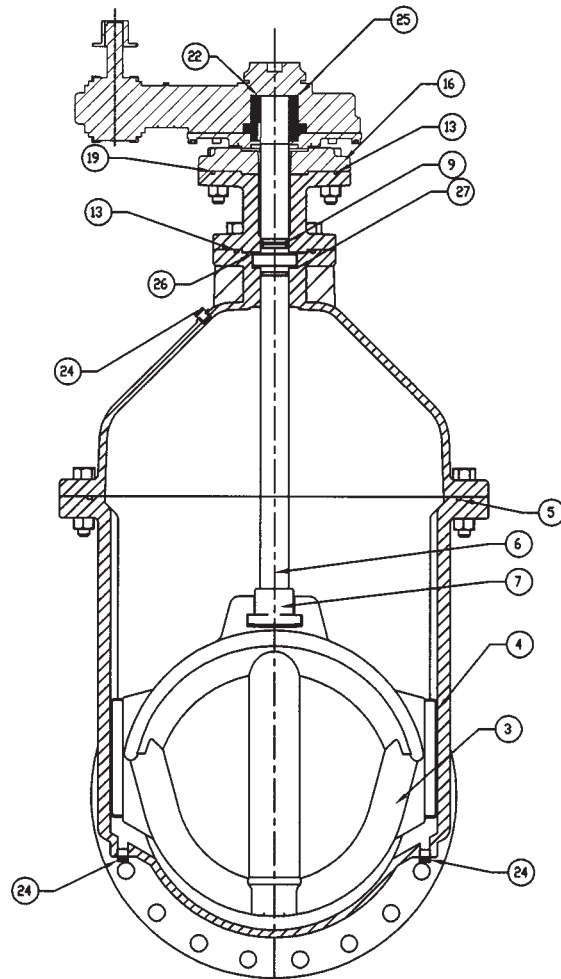
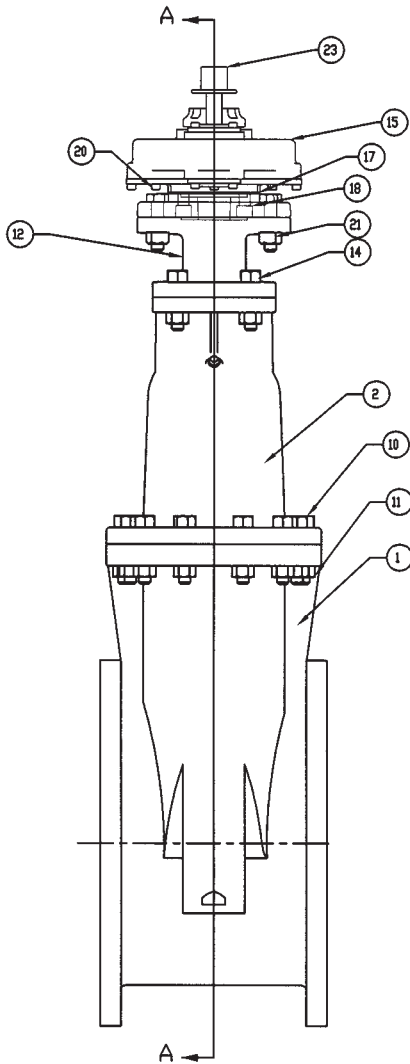

ITEM NO.	DESCRIPTION	MATERIAL
1	Body	Ductile Iron
2	Cover	Ductile Iron
3	Wedge	Ductile Iron/Rubber
4	Wedge Cap (18"-24" only)	Delrin
5	Oring	Rubber
6	Stem	Copper Alloy
7	Stem Nut	Copper Alloy
9	Oring	Rubber
10	Hex Head Bolt	Stainless Steel
11	Hex Nut	Stainless Steel
12	Extension	Ductile Iron
13	Oring	Rubber
14	Hex Head Bolt	Stainless Steel
15	Actuator - 3:1 (18-24") 2:1 (14-16")	
16	Adaptor Plate	Ductile Iron
17	Actuator Gasket	Rubber
18	Socket Head Bolt	Alloy Steel
19	Oring	Rubber
20	Hex Bolt	Stainless Steel
21	Hex Nut	Stainless Steel
22	Key	Steel
23	Op Nut	Ductile Iron
24	Pipe Plug - 3/4 NPT with square hd	Stainless Steel
25	Drive Sleeve	Steel
26	Thrust Bearing	Delrin
27	Thrust Bearing (18"-20" only)	Delrin

Complies with applicable requirements of AWWA C515

14"-20" R/W VALVE FLANGED END
BEVEL GEAR GENERAL DIMENSIONS

CLOW VALVE COMPANY

MODEL 2638

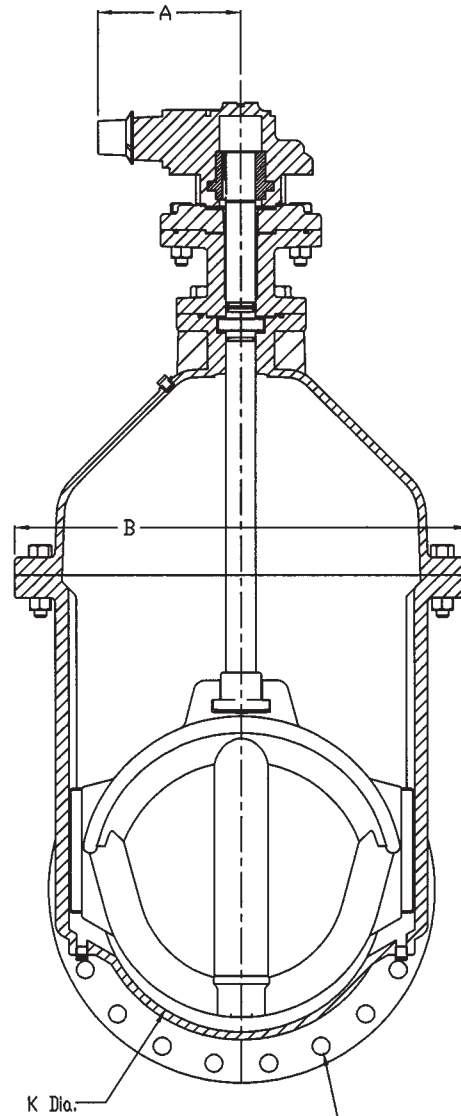
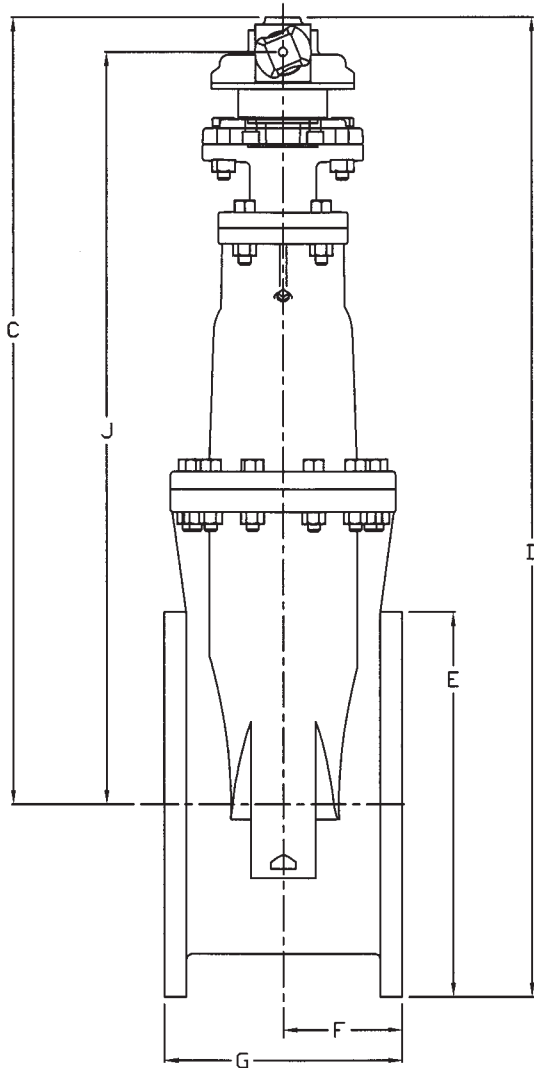

H- No. & size of bolts
Drilling Per ANSI B16.1
Class 125

VALVE SIZE	A	B	C	D	E	F	G	H	J	K
14	9 1/8	26 11/16	48 5/8	59 1/2	21	7 1/2	15	12-1	46 3/8	14 1/4
16	9 1/8	26 11/16	47 5/8	59 1/2	23 1/2	8	16	16-1	45 3/8	16 1/4
18	10 1/8	32 1/4	55 3/4	68 1/4	25	8 1/2	17	16-1 1/8	53 3/4	18 1/4
20	10 1/8	32 1/4	54 3/4	68 1/4	27 1/2	9	18	20-1 1/8	52 3/4	20 1/4

Complies with applicable requirements of AWWA C515

14"-20" R/W VALVE FLANGE
SPUR GEAR GENERAL DIMENSIONS

CLOW VALVE COMPANY

MODEL 2638

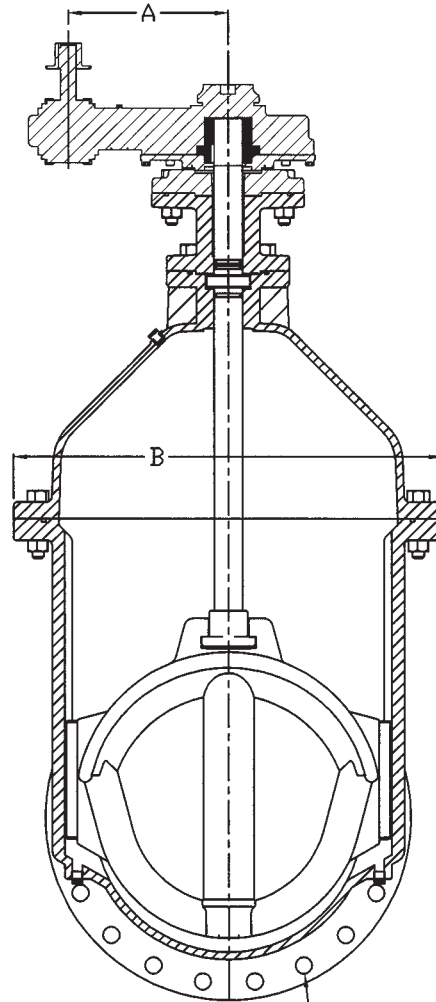
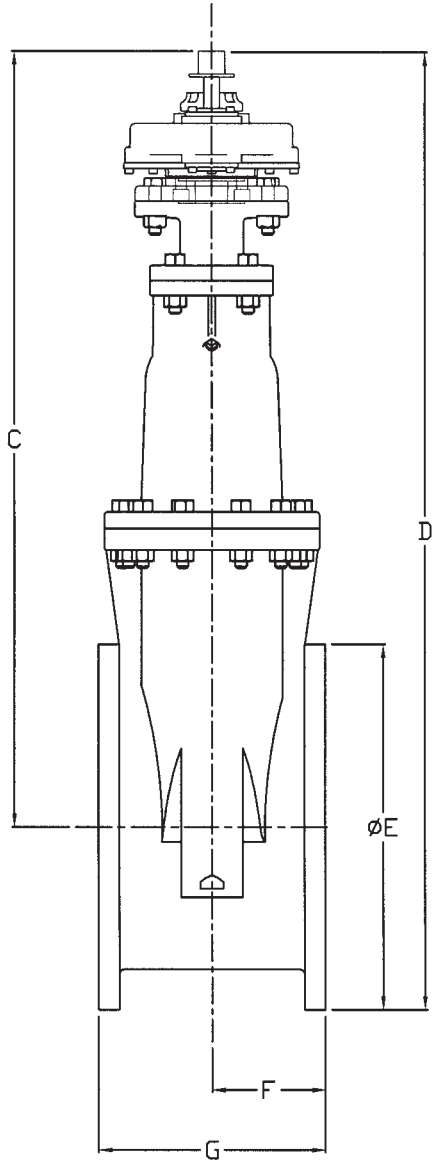

H - No. & size of bolts
Drilling per ANSI B16.1
Class 125

VALVE SIZE	A	B	C	D	E	F	G	H
14	8	26 11/16	52 1/8	63	21	7 1/2	15	12-1
16	8	26 11/16	51 1/8	63	23 1/2	8	16	16-1
18	12	32 1/4	58	70 1/2	25	8 1/2	17	16-1 1/8
20	12	32 1/4	57	70 1/2	27 1/2	9	18	20-1 1/8

Complies with applicable requirements of AWWA C515

14"-20" R/W VALVE MJ END
BEVEL GEAR GENERAL DIMENSIONS

CLOW VALVE COMPANY

MODEL 2638

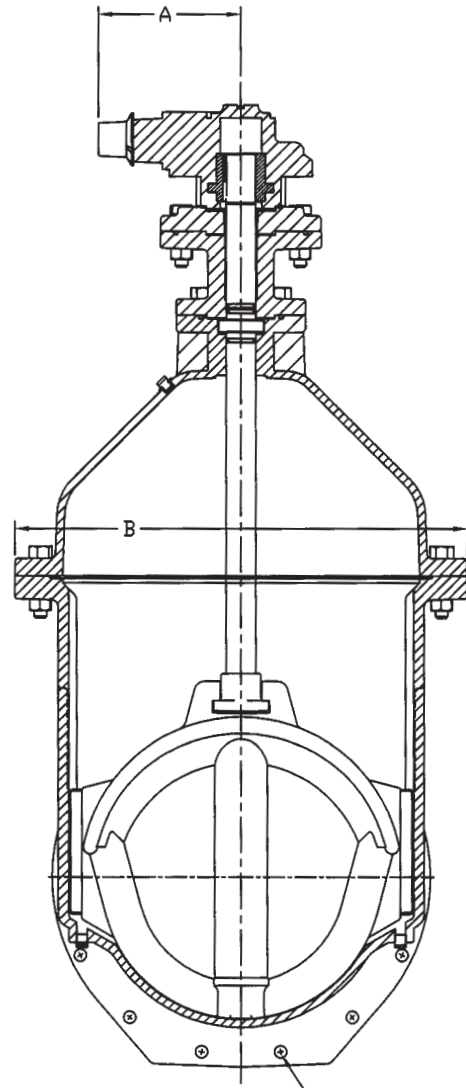
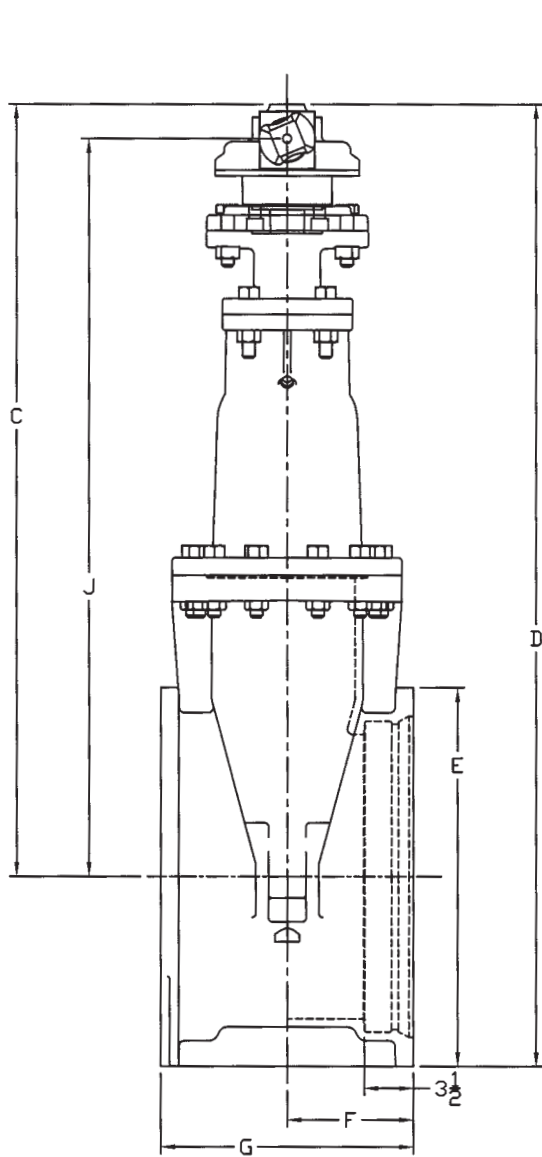

H- No. & size of bolts

VALVE SIZE	A	B	C	D	E	F	G	H	J
14	9 1/8	26 11/16	48 5/8	59	20 1/4	8 1/2	17	10-3/4	46 5/8
16	9 1/8	26 11/16	47 5/8	59	22 1/2	8 1/2	17	12-3/4	45 5/8
18	10 1/8	32 1/4	55 3/4	68 1/4	24 3/4	9 5/32	18 3/4	12-3/4	53 3/4
20	10 1/8	32 1/4	54 3/4	68 1/4	27	9	18	14-3/4	52 3/4

Complies with applicable requirements of AWWA C515

14"-20" R/W VALVE MJ END
SPUR GEAR GENERAL DIMENSIONS

CLOW VALVE COMPANY

MODEL 2638

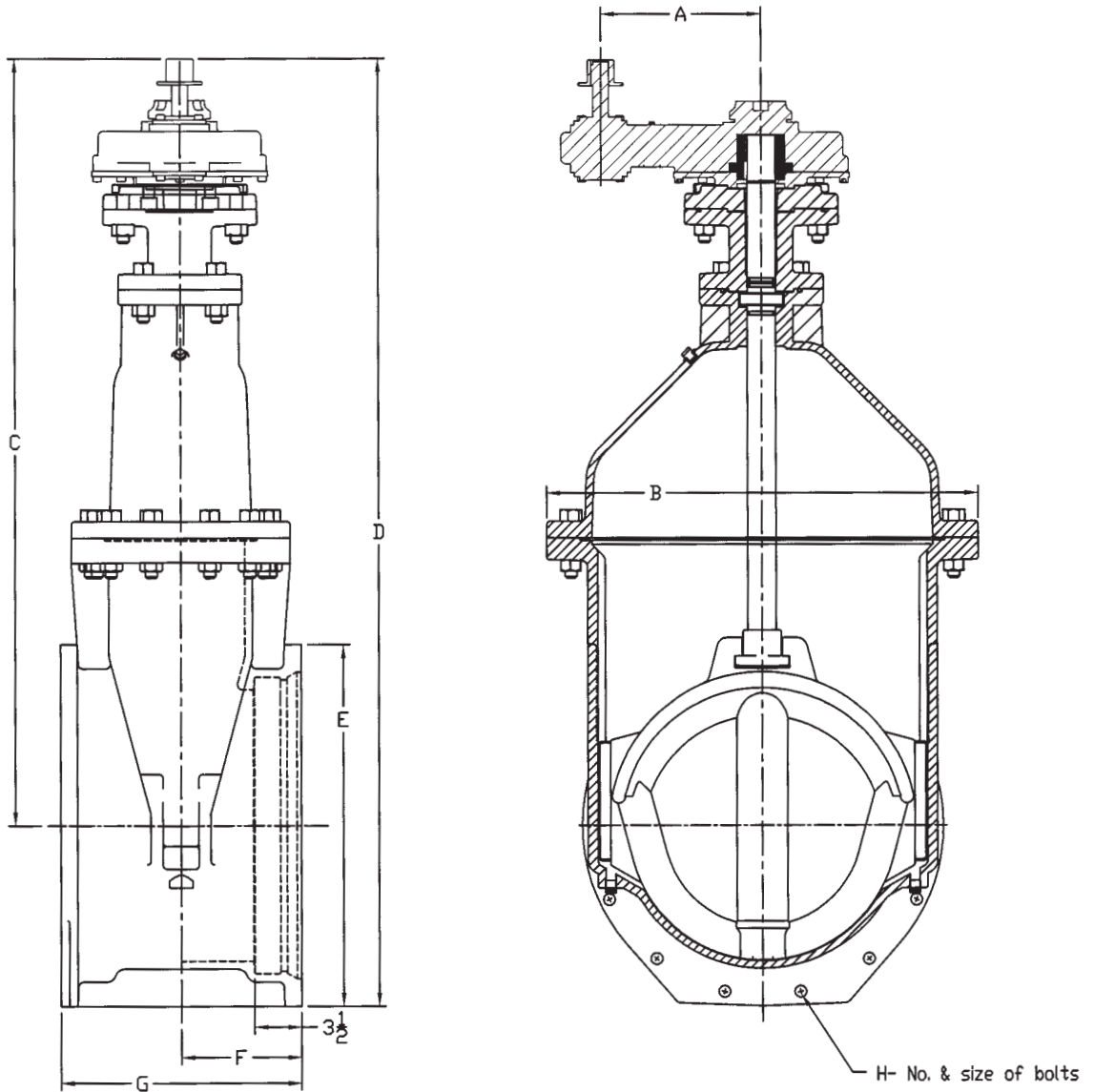

VALVE SIZE	A	B	C	D	E	F	G	H
14	8	26 11/16	52 1/8	62 1/2	20 1/4	8 1/2	17	10-3/4
16	8	26 11/16	51 1/8	62 1/2	22 1/2	8 1/2	17	12-3/4
18	12	32 1/4	58	70 1/2	24 3/4	9 5/32	18 3/4	12-3/4
20	12	32 1/4	57	70 1/2	27	9 5/32	18	14-3/4

Complies with applicable requirements of AWWA C515

14"-20" R/W VALVE MJ x FLANGE END
BEVEL GEAR GENERAL DIMENSIONS

CLOW VALVE COMPANY

MODEL 2638

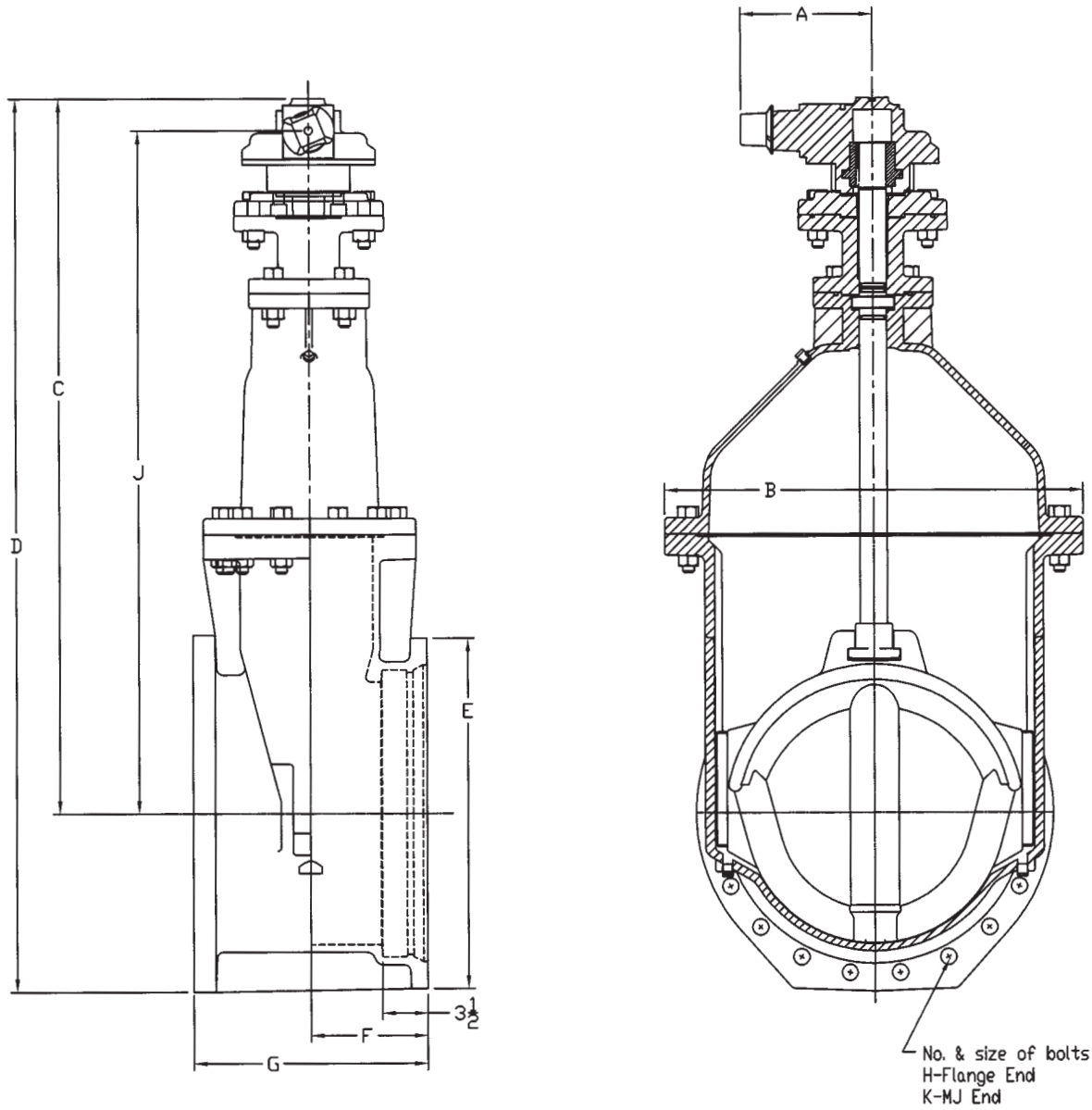

VALVE SIZE	A	B	C	D	E	F	G	H	J	K
14	9 1/8	26 11/16	48 5/8	59 1/2	20 1/4	8 1/2	17	12-1 1/8	46 3/8	10-3/4
16	9 1/8	26 11/16	47 5/8	59 1/2	22 1/2	8 1/2	16 1/2	16-1	45 3/8	12-3/4
18	10 1/8	32 1/4	55 3/4	68 3/4	24 3/4	9 3/8	18 3/8	16-1 1/8	53 3/4	12-3/4
20	10 1/8	32 1/4	54 3/4	68 3/4	27	9 5/32	18	20-1 1/8	52 3/4	14-3/4

Complies with applicable requirements of AWWA C515

14"-20" R/W VALVE MJ x FLANGE END
SPUR GEAR GENERAL DIMENSIONS

CLOW VALVE COMPANY

MODEL 2638

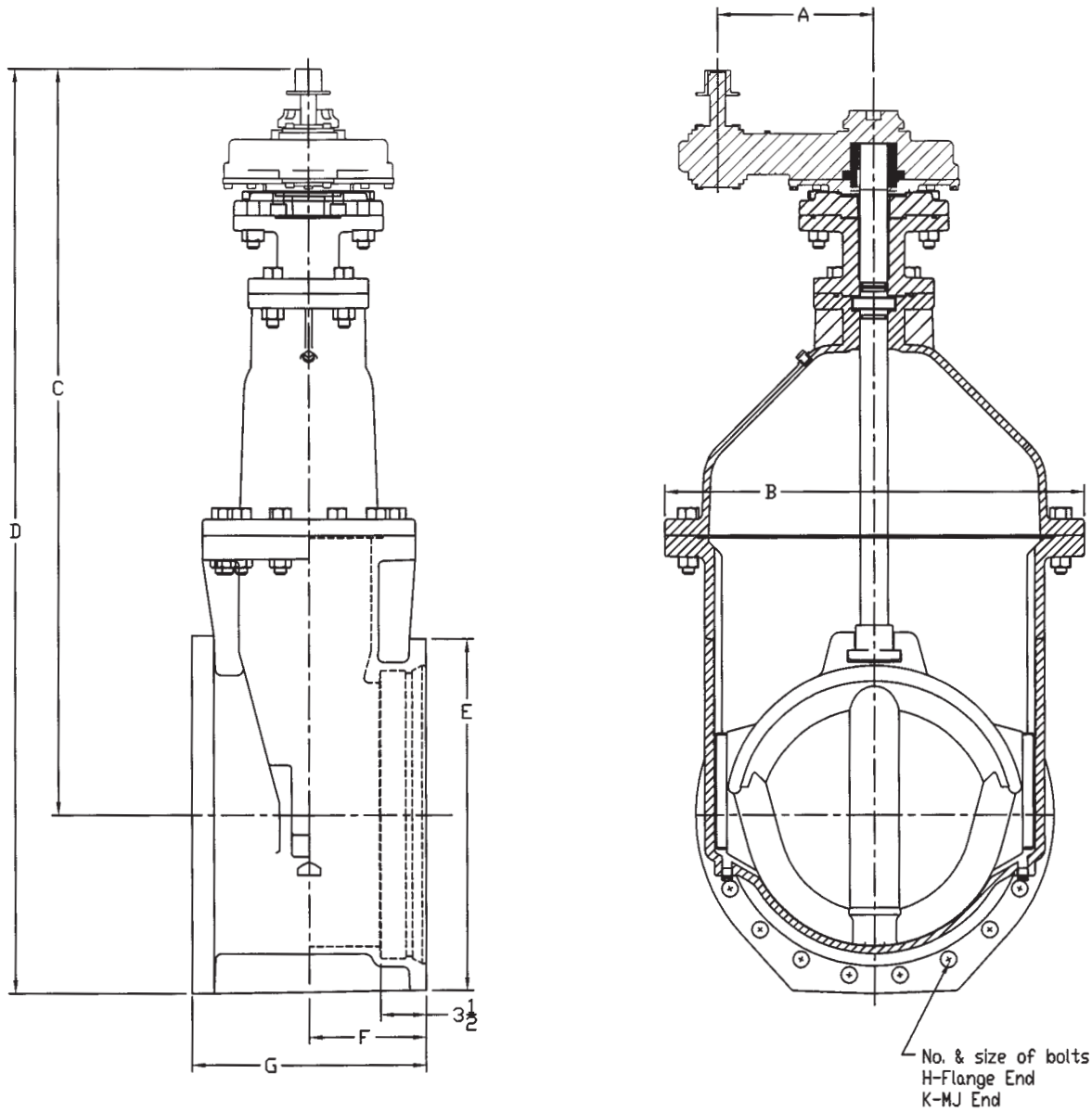

VALVE SIZE	A	B	C	D	E	F	G	H	K
14	8	26 11/16	52 1/8	62 1/2	20 1/4	8 1/2	17	12-1 1/8	10-3/4
16	8	26 11/16	51 1/8	62 1/2	22 1/2	8 1/2	16 1/2	16-1	12-3/4
18	12	32 1/4	58	70 1/2	24 3/4	9 3/8	18 3/8	16-1 1/8	12-3/4
20	12	32 1/4	57	70 1/2	27	9 5/32	18	20-1 1/8	14-3/4

Complies with applicable requirements of AWWA C515

14"-20" R/W VALVE MJ TAP END
BEVEL GEAR GENERAL DIMENSIONS

CLOW VALVE COMPANY

MODEL 2638

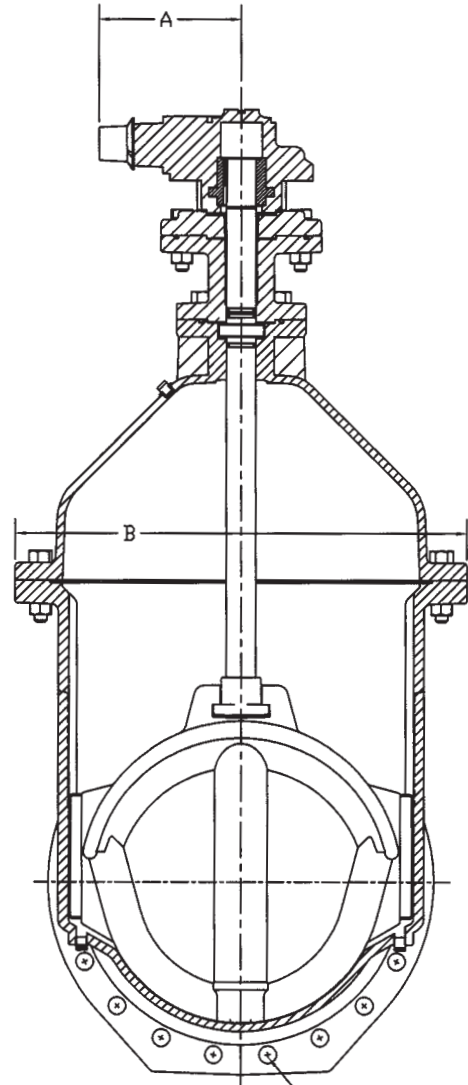
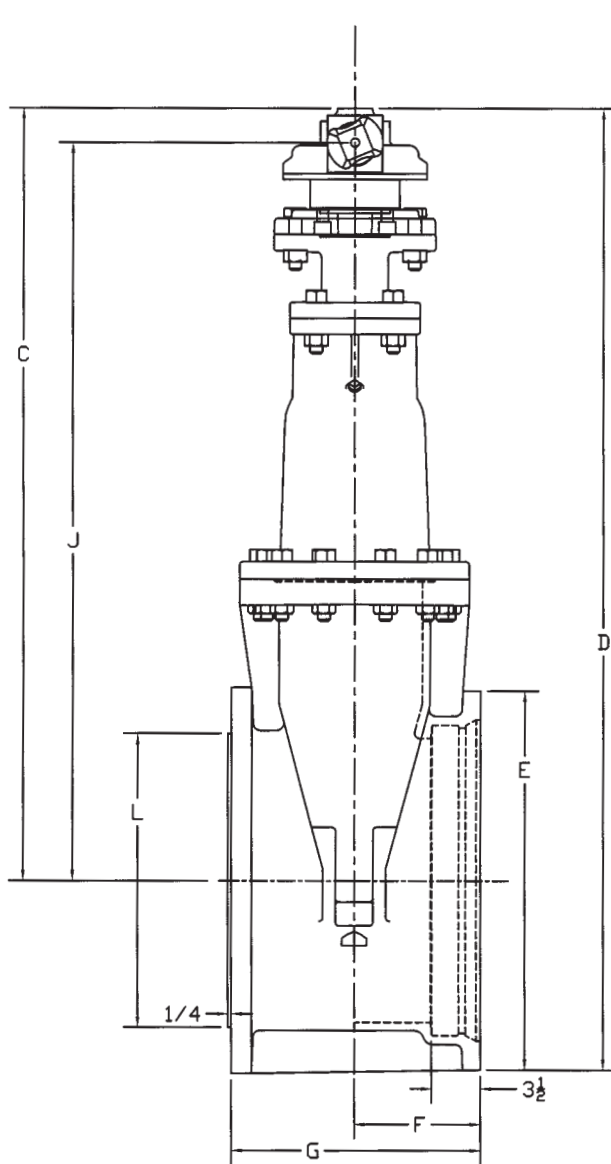

No. & size of bolts
H-Flange End
K-MJ End

VALVE SIZE	A	B	C	D	E	F	G	H	J	K	L
14	9 1/8	26 11/16	48 5/8	59 1/2	20 1/4	8 1/2	16 3/4	12-1	46 3/8	10-3/4	14 15/16
16	9 1/8	26 11/16	47 5/8	59 1/2	22 1/2	8 1/2	16 1/4	16-1	45 3/8	12-3/4	16 15/16
18	10 1/8	32 1/4	55 3/4	68 3/4	24 3/4	9 3/8	18 1/8	16-1 1/8	53 3/4	12-3/4	18 15/16
20	10 1/8	32 1/4	54 3/4	68 3/4	27	9	18	20-1 1/8	52 3/4	14-3/4	20 15/16

Complies with applicable requirements of AWWA C515

14"-20" R/W VALVE MJ TAP END
SPUR GEAR GENERAL DIMENSIONS

CLOW VALVE COMPANY

MODEL 2638

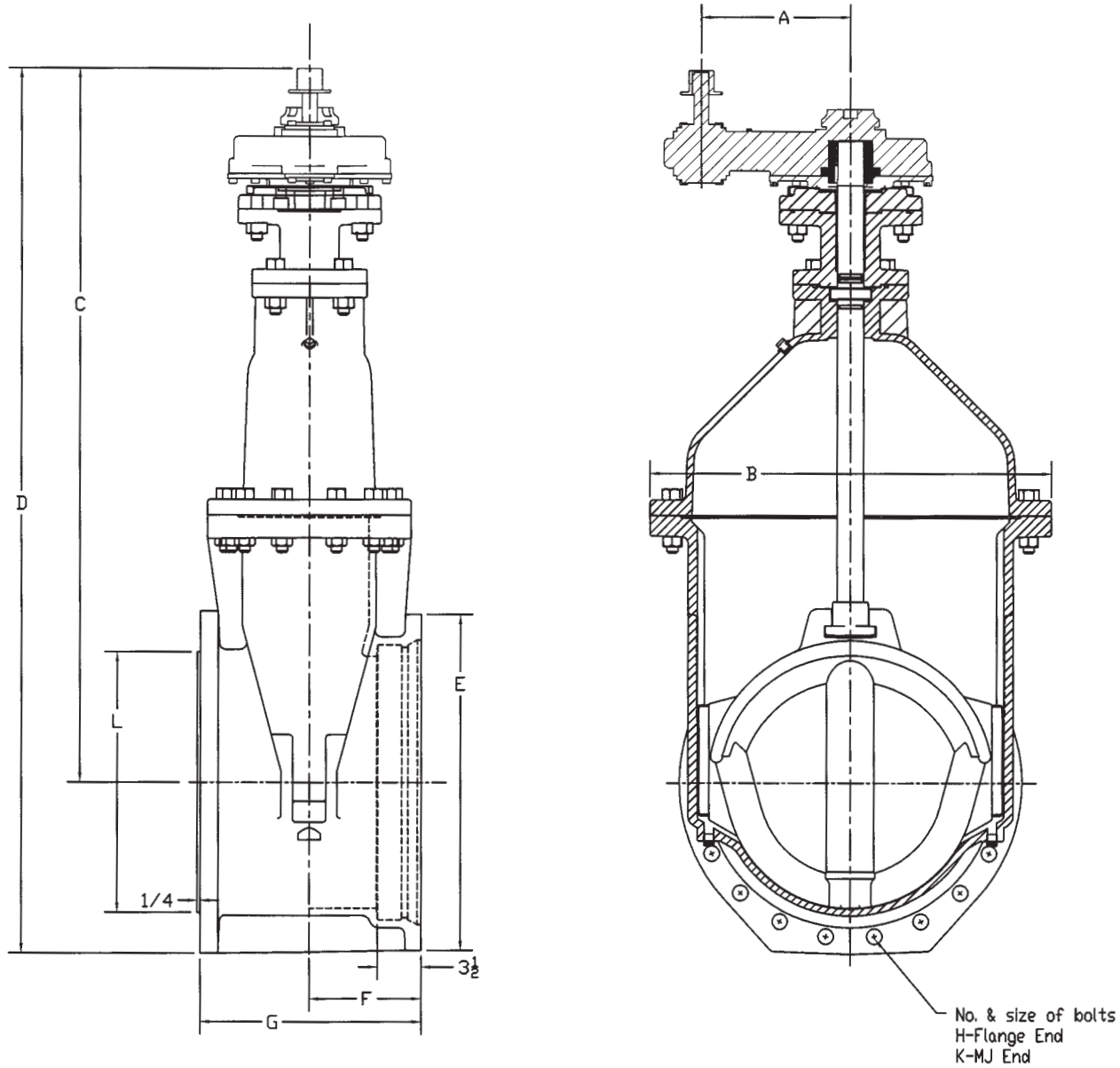

VALVE SIZE	A	B	C	D	E	F	G	H	K	L
14	8	26 11/16	52 1/8	62 1/2	20 1/4	8 1/2	16 3/4	12-1	10-3/4	14 15/16
16	8	26 11/16	51 1/8	62 1/2	22 1/2	8 1/2	16 1/4	16-1	12-3/4	16 15/16
18	12	32 1/4	58	70 1/2	24 3/4	9 3/8	18 1/8	16-1 1/8	12-3/4	18 15/16
20	12	32 1/4	57	70 1/2	27	9	18	20-1 1/8	14-3/4	20 15/16

Complies with applicable requirements of AWWA C515

14"-20" R/W OS&Y WITH HW
SPUR GEAR ACTUATOR

CLOW VALVE COMPANY

MODEL 2638

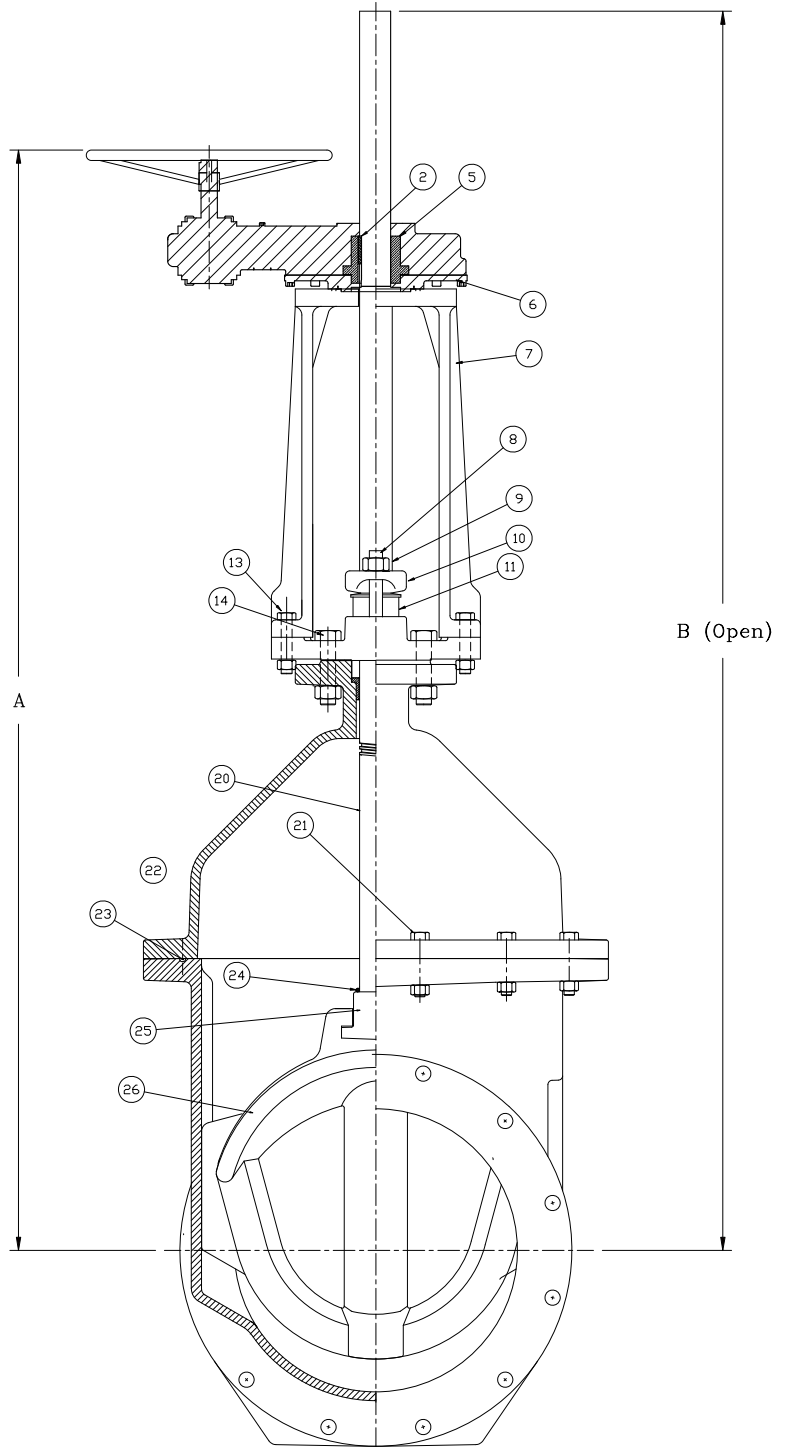
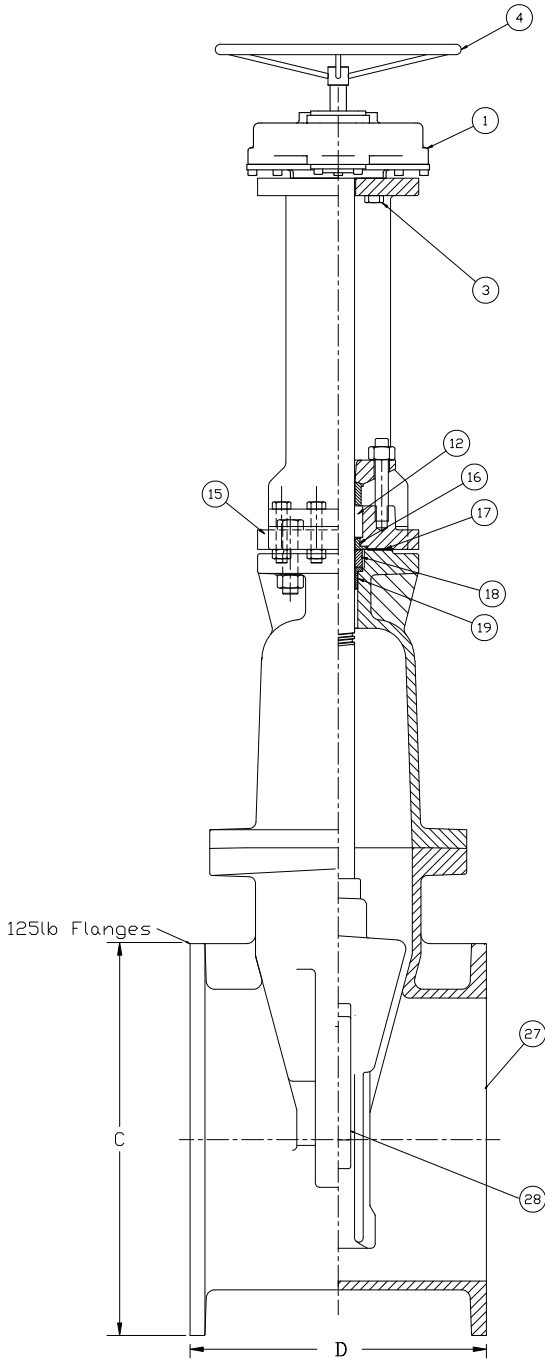

Item	Description	
1	Exeeco 1S7	Bronze ASTM B584 C83600
2	Square Key	Commercial Steel
3	Hex Capscrew	Stainless Steel ASTM F593/F594 304
4	Handwheel	Steel
5	Output Sleeve	Aluminum Bronze ASTM B505 C95800
6	Roll Pin	Stainless Steel
7	Yoke	Gray Iron ASTM A126 Class B
8	Stud	316 Stainless Steel
9	Hex Nut	Bronze
10	Follower	Gray Iron ASTM A126 Class B
11	Gland	Bronze ASTM B584 C83600
12	Packing	Square braided Fibre
13	Hex Capscrew & Hex Nut	Stainless Steel ASTM F593/F594 304
14	Hex Capscrew & Hex Nut	Stainless Steel ASTM F593/F594 304
15	Adapter	Gray Iron ASTM A126 Class B
16	Bushing	Bronze ASTM B584 C83600
17	Follower Gasket	Fibre
18	Cover Spacer	Bronze ASTM B584 C83600
19	Cover Bushing	Bronze ASTM B584 C83600
20	Stem & Bottom Nut	Bronze ASTM B148 C95400 & B584 C83600
21	Hex Capscrew & Hex Nut	Stainless Steel ASTM F593/F594 304
22	Cover	Ductile Iron ASTM A536 Grade 65-45-12
23	Cover O-Ring	EPDM
24	Stem O-Ring	EPDM
25	Stem Nut	Bronze ASTM B584 C83600
26	Wedge	Ductile Iron ASTM A536 65-45-12 & EPDM
27	Body -flanged type	Ductile Iron ASTM A536 Grade 65-45-12
28	Wedge Protector Cap	Delrin

	14"	16"	18"	20"
A	64 1/2	64 1/2	74 5/8	74 5/8
B	76	76	90 7/8	90 7/8
C	21	23 1/2	25	27 1/2
D	15	16	17	18

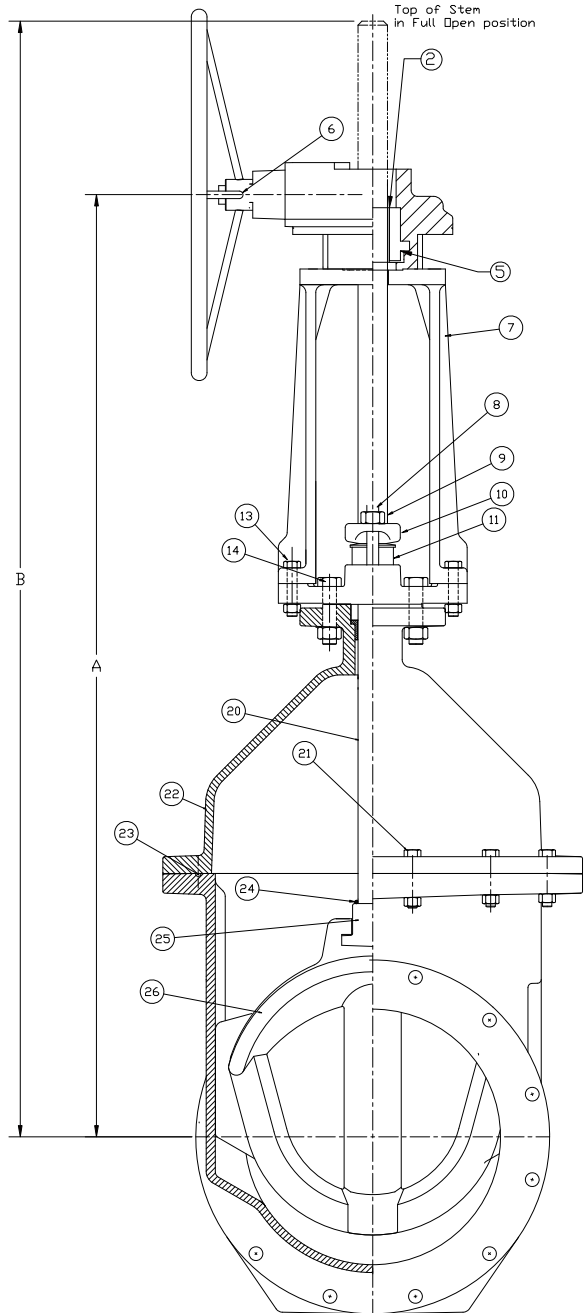
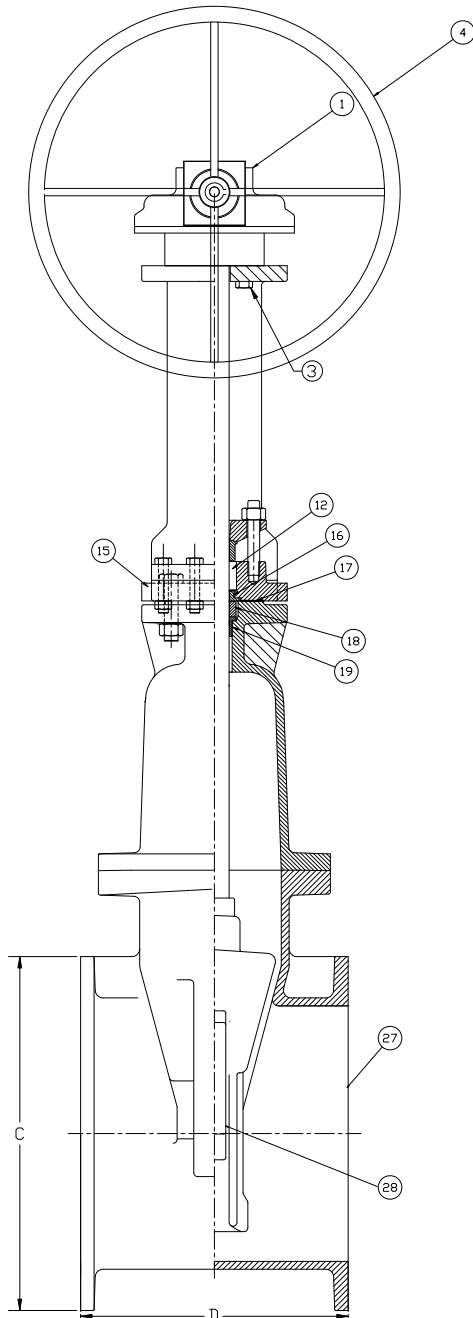

Item	Description	
1	Exeeco IB7	
2	Square Key	Commercial Steel
3	Hex Capscrew	Stainless Steel ASTM F593/F594 304
4	Handwheel	Steel
5	Output Sleeve	Aluminum Bronze ASTM B505 C95800
6	Roll Pin	Stainless Steel
7	Yoke	Gray Iron ASTM A126 Class B
8	Stud	316 Stainless Steel
9	Hex Nut	Bronze
10	Follower	Gray Iron ASTM A126 Class B
11	Gland	Bronze ASTM B584 C83600
12	Packing	Square braided Fibre
13	Hex Capscrew & Hex Nut	Stainless Steel ASTM F593/F594 304
14	Hex Capscrew & Hex Nut	Stainless Steel ASTM F593/F594 304
15	Adapter	Gray Iron ASTM A126 Class B
16	Bushing	Bronze ASTM B584 C83600
17	Follower Gasket	Fibre
18	Cover Spacer	Bronze ASTM B584 C83600
19	Cover Bushing	Bronze ASTM B584 C83600
20	Stem & Bottom Nut	Bronze ASTM B148 C95400 & B584 C83600
21	Hex Capscrew & Hex Nut	Stainless Steel ASTM F593/F594 304
22	Cover	Ductile Iron ASTM A536 Grade 65-45-12
23	Cover O-Ring	NBR
24	Stem O-Ring	NBR
25	Stem Nut	Bronze ASTM B584 C83600
26	Wedge	Ductile Iron ASTM A536 65-45-12 & EPDM
27	Body -flanged type	Ductile Iron ASTM A536 Grade 65-45-12
28	Wedge Protector Cap	Delrin

	14"	16"	18"	20"
A	59 7/8	59 7/8	70 1/8	70 1/8
B	76	76	90 7/8	90 7/8
C	21	23 1/2	25	27 1/2
D	15	16	17	18

2638-84 Cat
F 10/10

Complies with applicable
requirements of AWWA C515

24" R/W RTS Bevel Gear
Parts List

CLOW VALVE COMPANY

MODEL 2638

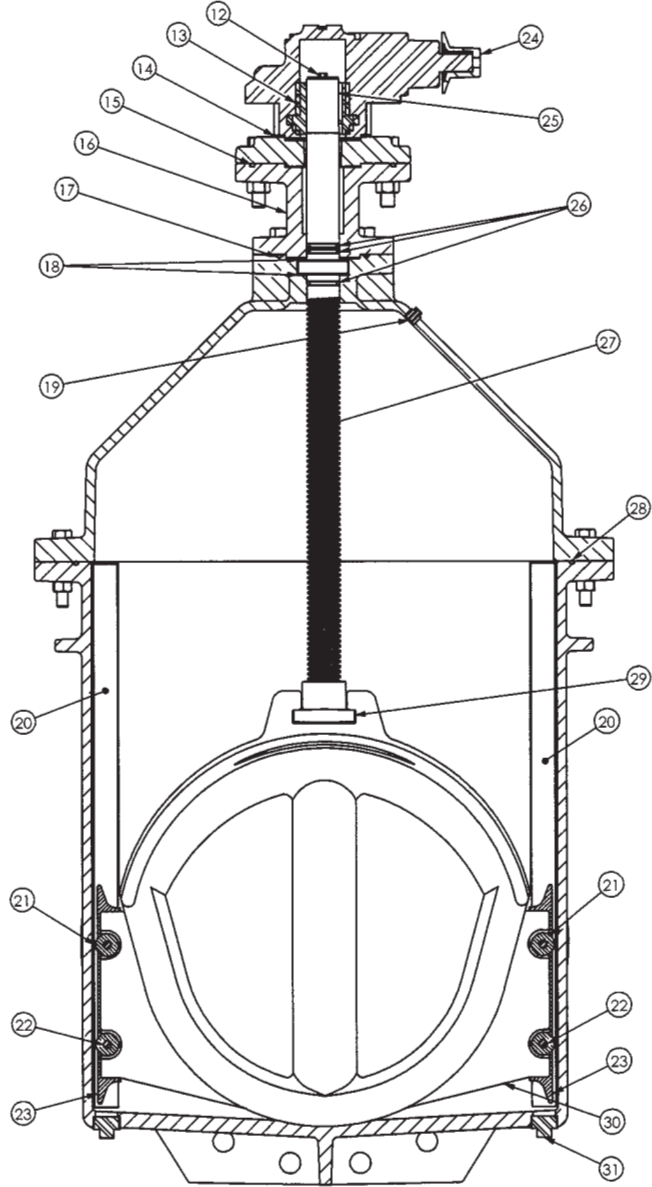
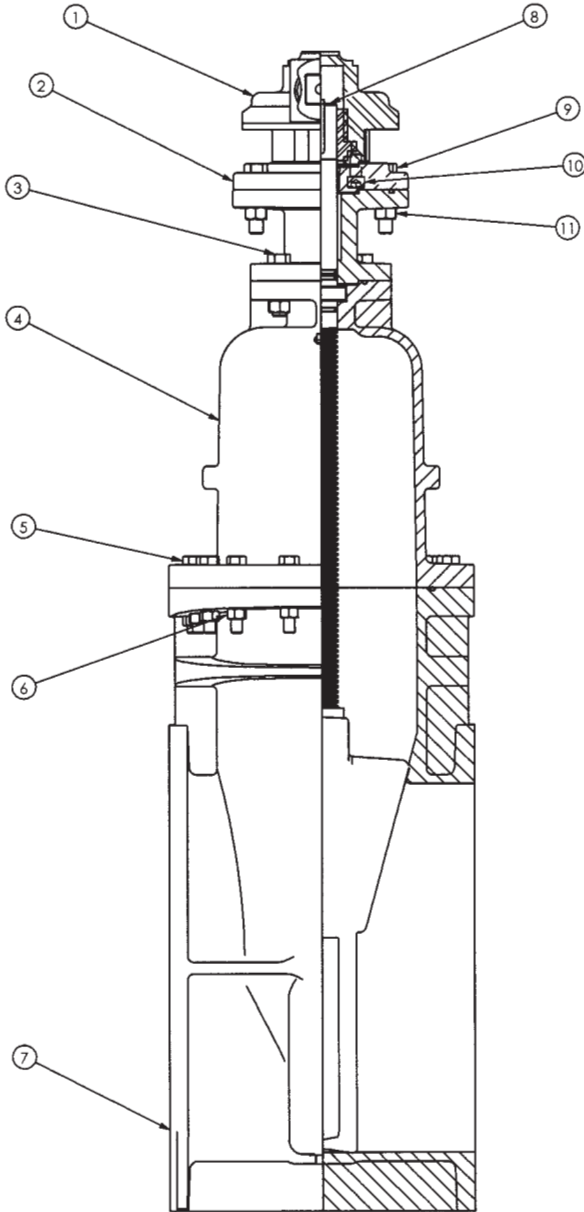

ITEM NO.	DESCRIPTION	MATERIAL	ITEM NO.	DESCRIPTION	MATERIAL
1	Exeeco IB7 3:1 Actuator	-	18	Thrust Washer	Plastic
2	Adaptor Plate	Ductile Iron	19	Pipe Plug	Stainless Steel
3	Hex Head Bolt	Stainless Steel	20	Track	Stainless Steel
4	Cover	Ductile Iron	21	Roller	Copper Alloy
5	Hex Head Bolt	Stainless Steel	22	Pin	Stainless Steel
6	Hex Nut	Stainless Steel	23	Scraper	Copper Alloy
7	Body - Flange	Ductile Iron	24	Op Nut	Ductile Iron
8	Washer	Steel	25	Key	Steel
9	Head Head Bolt	Stainless Steel	26	O-Ring	Rubber
10	Socket Head Bolt	Stainless Steel	27	Stem	Copper Alloy
11	Hex Nut	Stainless Steel	28	O-Ring	Rubber
12	Hex Head Bolt	Stainless Steel	29	Stem Nut	Copper Alloy
13	Drive Steeve	Steel	30	Wedge	Ductile Iron / Rubber
14	Actuator Gasket	Rubber	31	Pipe Plug	Stainless Steel
15	O-Ring	Rubber			
16	Extension	Ductile Iron			
17	O-Ring	Rubber			

2638-85
D 10/10

Complies with applicable
requirements of AWWA C515

24" R/W RTS Bevel Gear Flange Ends
General Dimensions

CLOW VALVE COMPANY

MODEL 2638

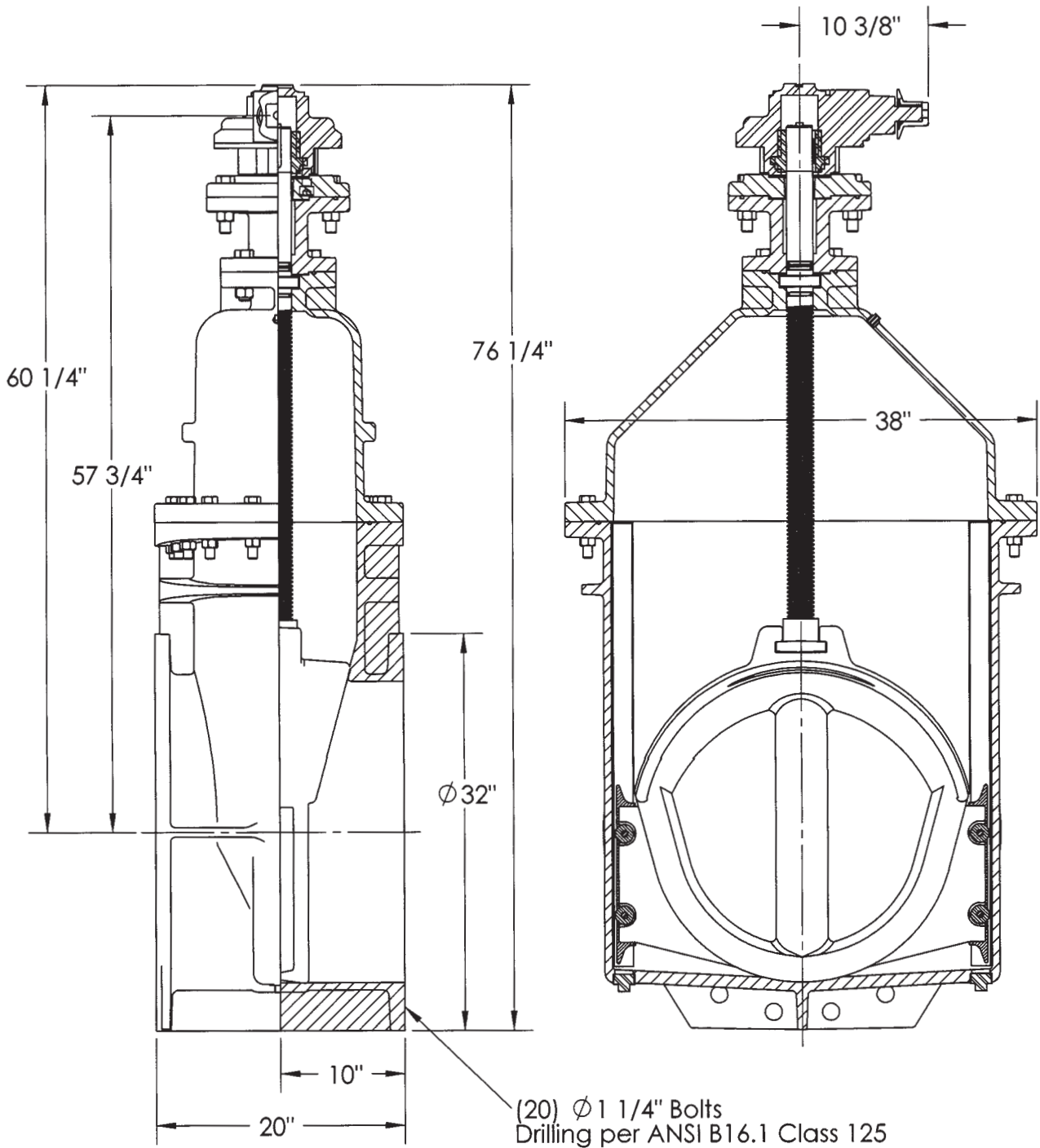

2638-87
D 10/10

Complies with applicable
requirements of AWWA C515

24" R/W RTS Bevel Gear MJ Ends
General Dimensions

CLOW VALVE COMPANY

MODEL 2638

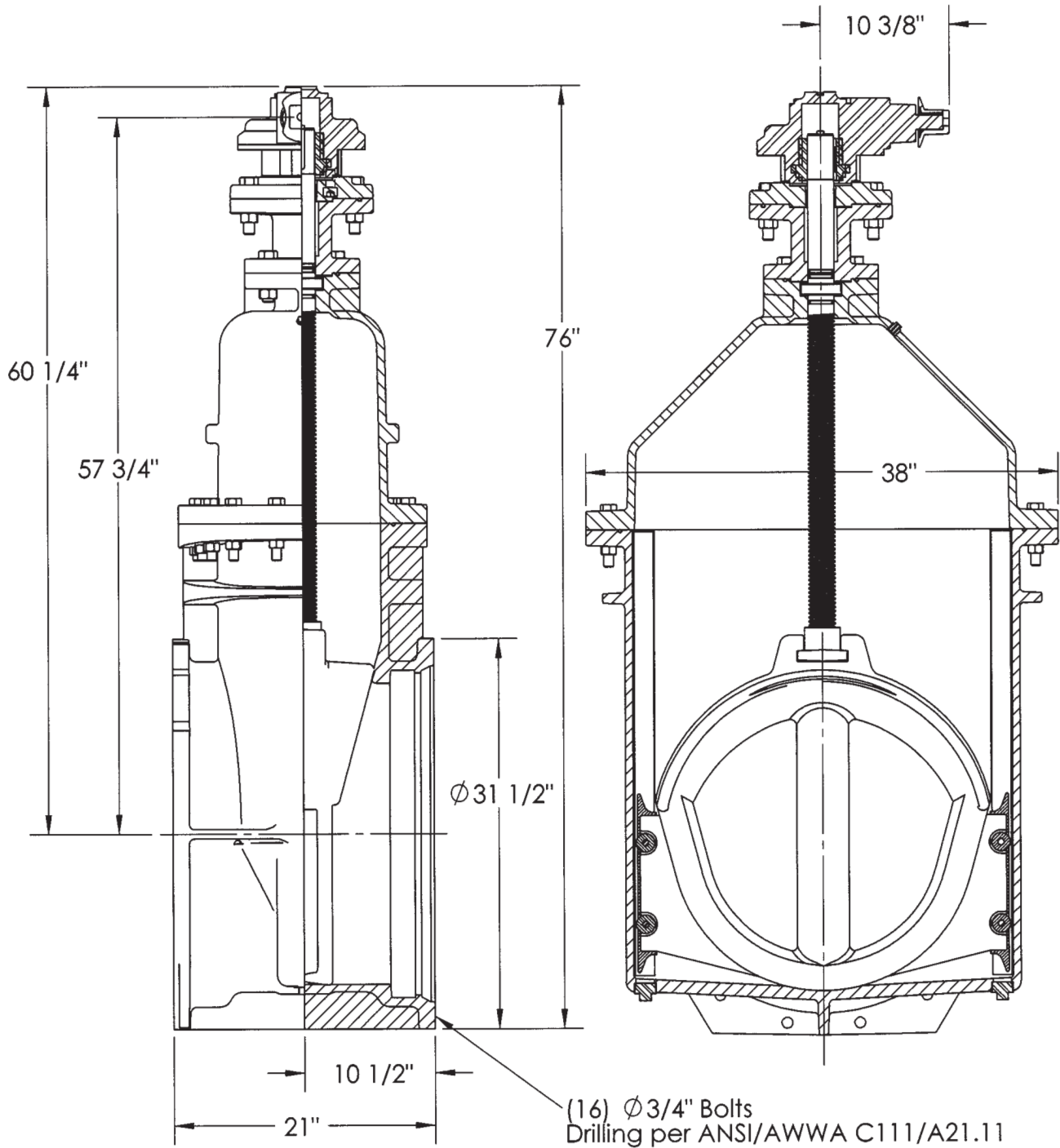

2638-88
C 10/10

Complies with applicable requirements of AWWA C515

24" R/W RTS Bevel Gear MJ x Flange
General Dimensions

CLOW VALVE COMPANY

MODEL 2638

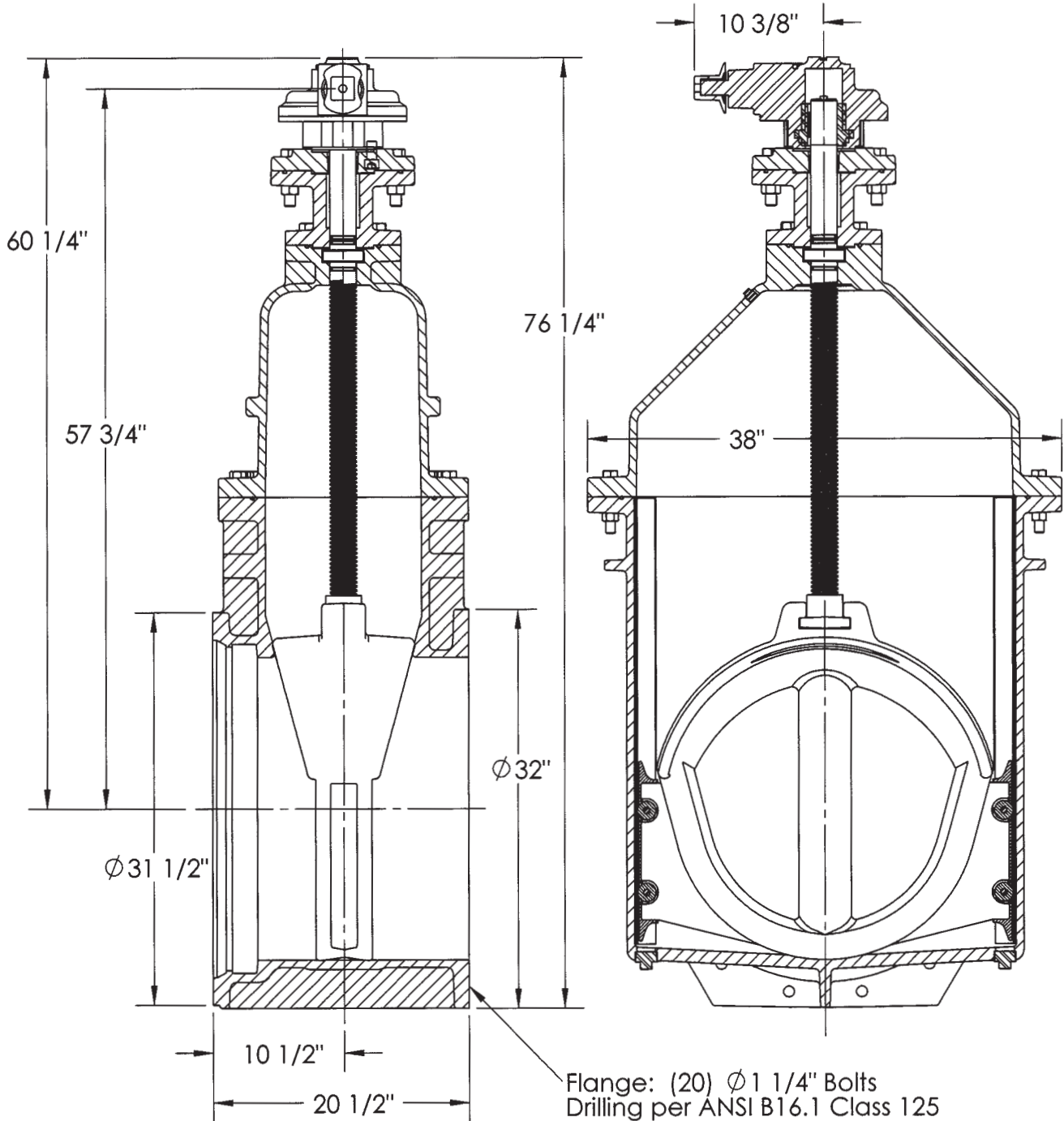

Flange: (20) ϕ 1 1/4" Bolts
Drilling per ANSI B16.1 Class 125

MJ: (16) ϕ 3/4" Bolts
Drilling per ANSI/AWWA C111/A21.11

2638-89
E 10/10

Complies with applicable requirements of AWWA C515

24" R/W RTS Bevel Gear MJ x Tap
General Dimensions

CLOW VALVE COMPANY

MODEL 2638

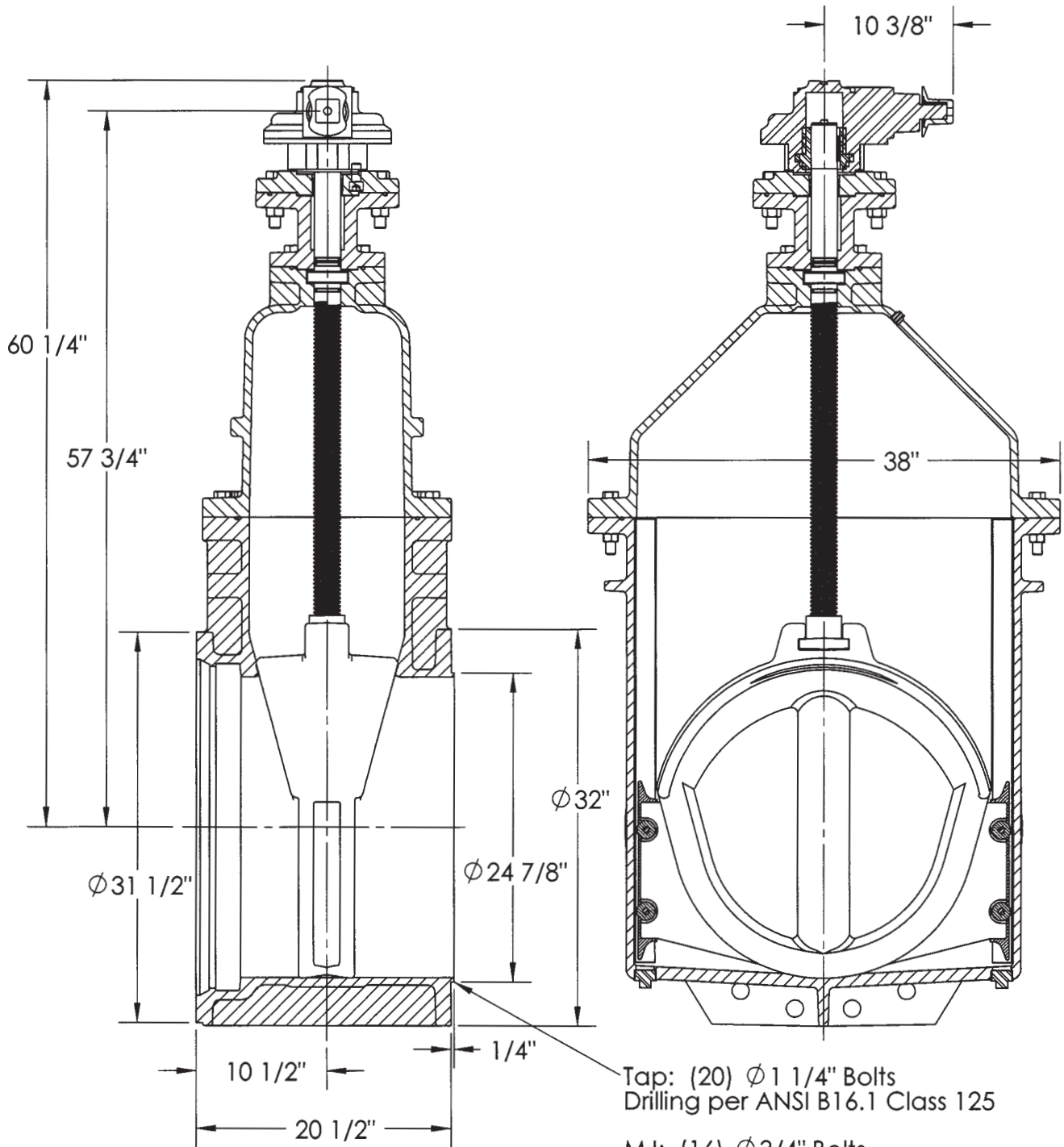

Accommodates a full size diameter cutter

2638-90 Cat
F 10/10

Complies with applicable
requirements of AWWA C515

24" R/W RTS Spur Gear
Parts List

CLOW VALVE COMPANY

MODEL 2638

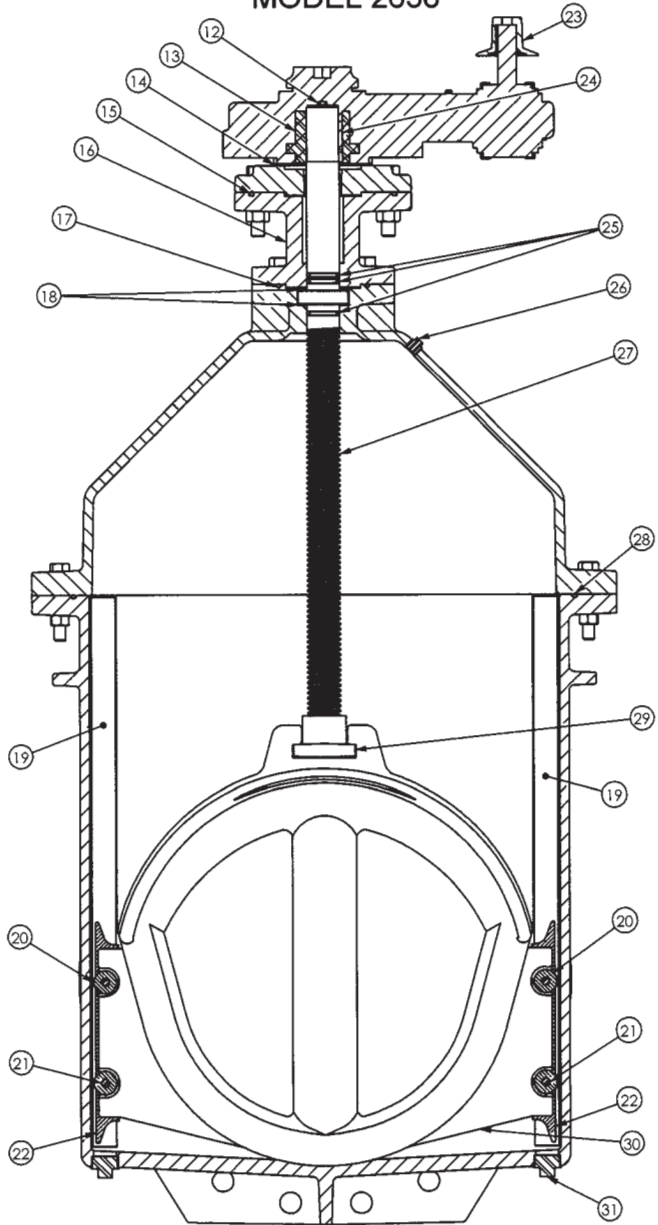
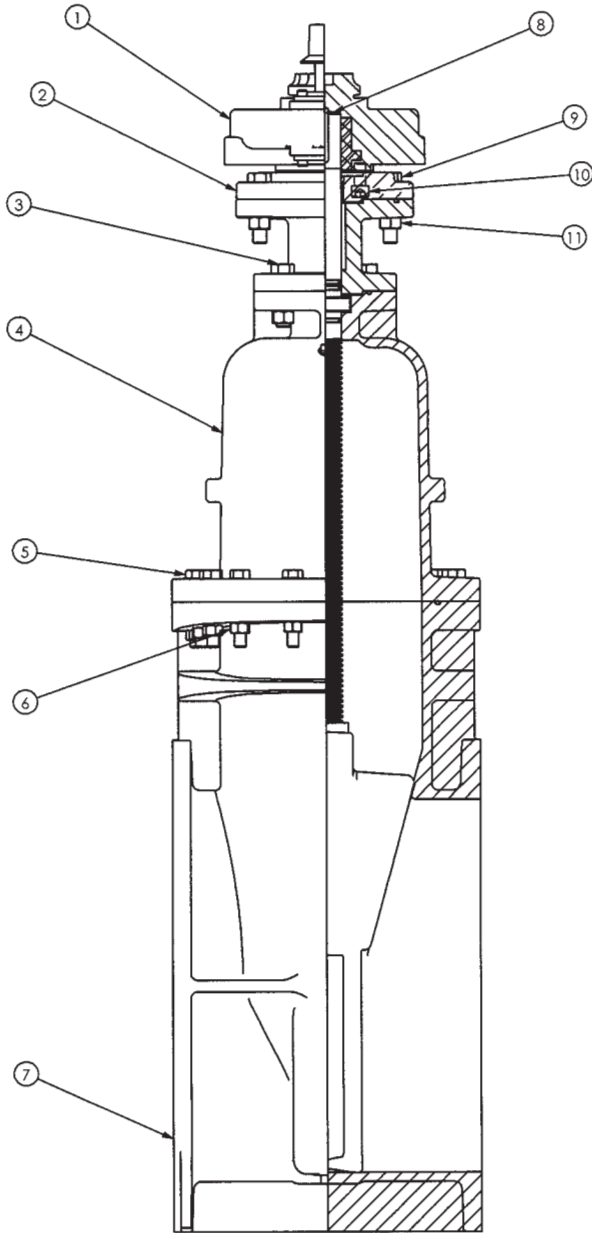

ITEM NO.	DESCRIPTION	MATERIAL	ITEM NO.	DESCRIPTION	MATERIAL
1	Exeeco IS7 3:1 Actuator	-	18	Thrust Washer	Plastic
2	Adaptor Plate	Ductile Iron	19	Track	Stainless Steel
3	Hex Head Bolt	Stainless Steel	20	Roller	Copper Alloy
4	Cover	Ductile Iron	21	Pin	Stainless Steel
5	Hex Head Bolt	Stainless Steel	22	Scraper	Copper Alloy
6	Hex Nut	Stainless Steel	23	Op Nut	Ductile Iron
7	Body - Flange	Ductile Iron	24	Key	Steel
8	Washer	Steel	25	O-Ring	Rubber
9	Head Head Bolt	Stainless Steel	26	Pipe Plug	Stainless Steel
10	Socket Head Bolt	Stainless Steel	27	Stem	Copper Alloy
11	Hex Nut	Stainless Steel	28	O-Ring	Rubber
12	Hex Head Bolt	Stainless Steel	29	Stem Nut	Copper Alloy
13	Drive Sleeve	Steel	30	Wedge	Ductile Iron / Rubber
14	Actuator Gasket	Rubber	31	Pipe Plug	Stainless Steel
15	O-Ring	Rubber			
16	Extension	Ductile Iron			
17	O-Ring	Rubber			

2638-91
D 10/10

Complies with applicable
requirements of AWWA C515

24" R/W RTS Spur Gear Flange Ends
General Dimensions

CLOW VALVE COMPANY

MODEL 2638

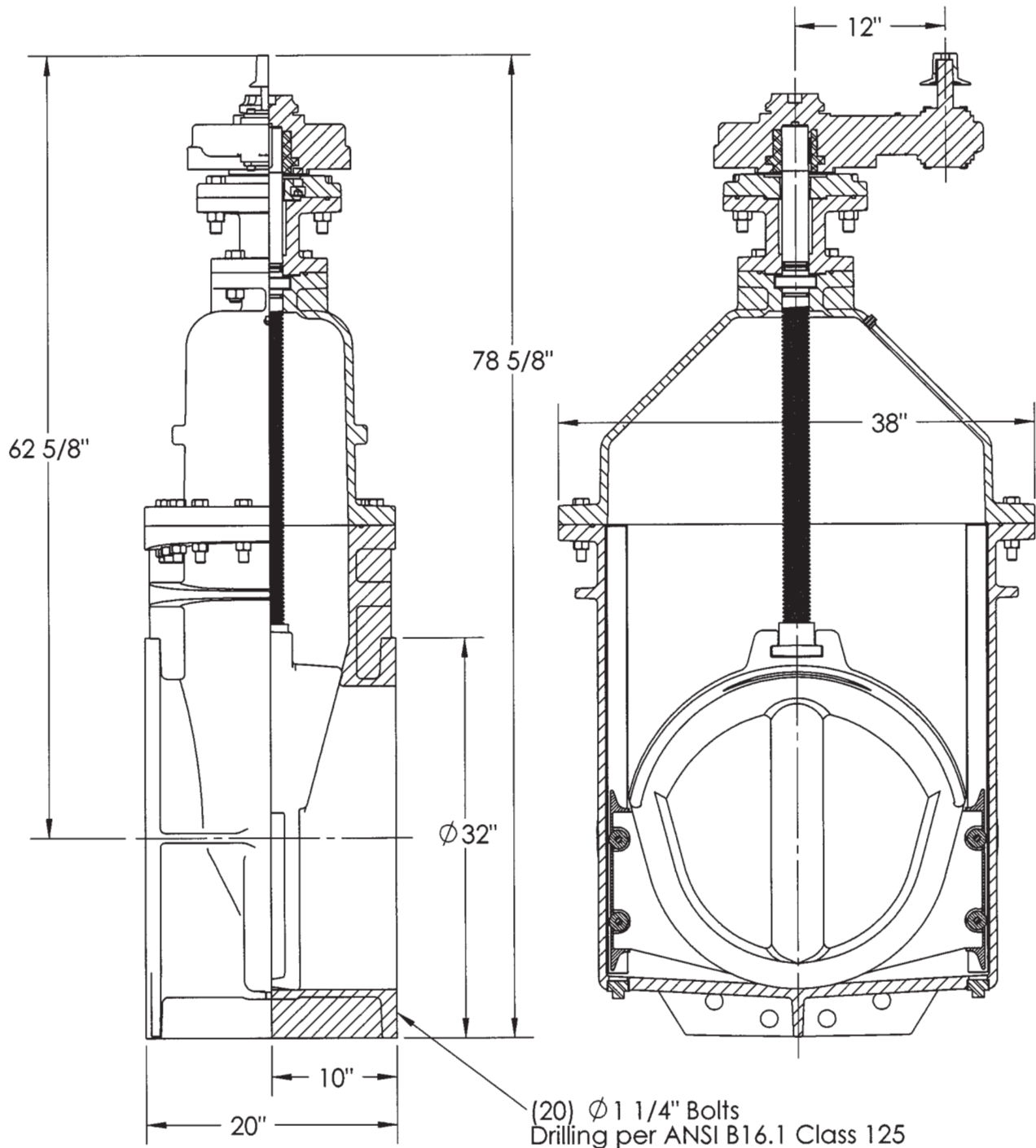

2638-92
D 10/10

Complies with applicable
requirements of AWWA C515

24" R/W RTS Spur Gear MJ Ends
General Dimensions

CLOW VALVE COMPANY

MODEL 2638

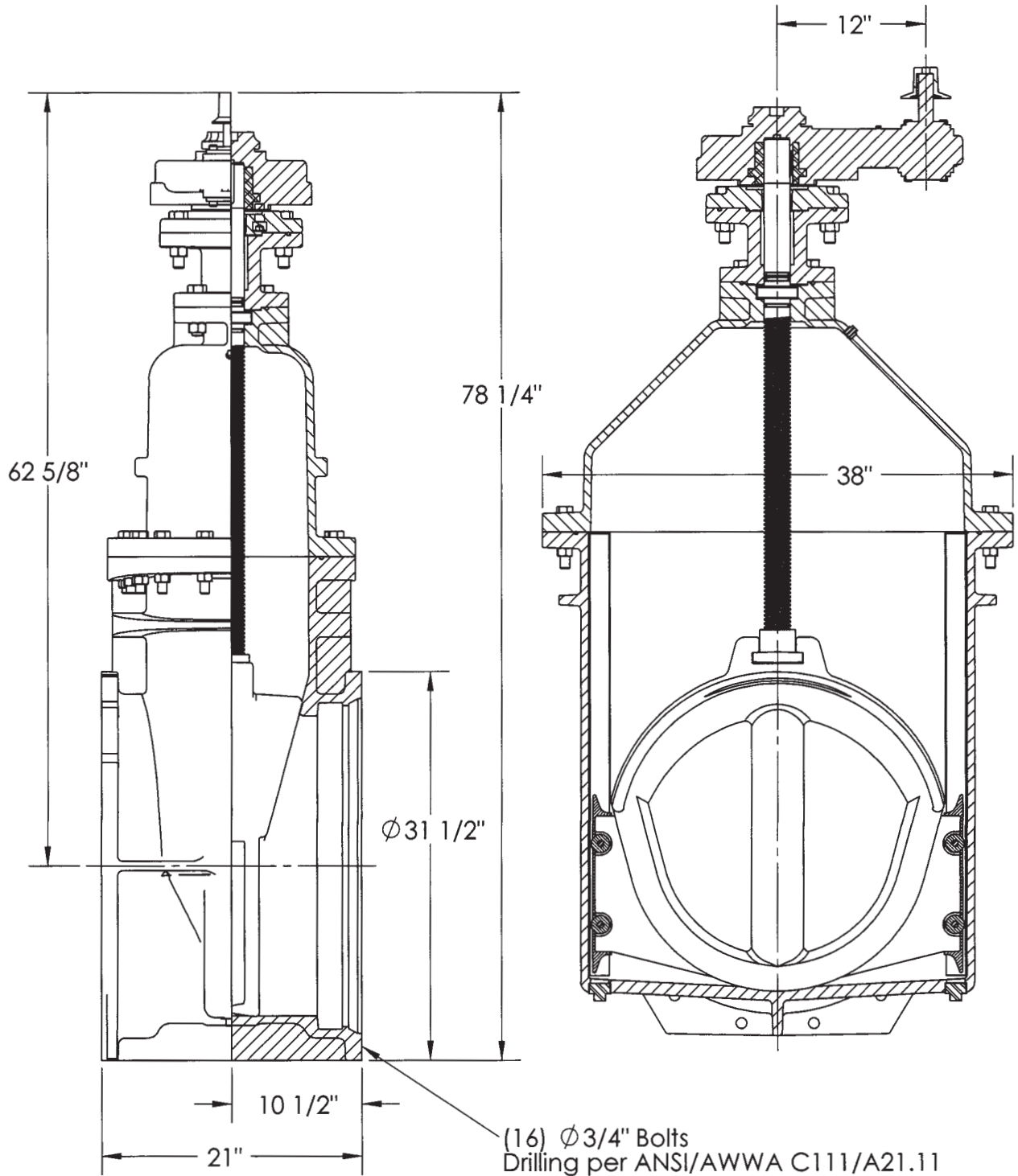

2638-93
E 10/10

Complies with applicable
requirements of AWWA C515

24" R/W RTS Spur Gear MJ x Flange
General Dimensions

CLOW VALVE COMPANY

MODEL 2638

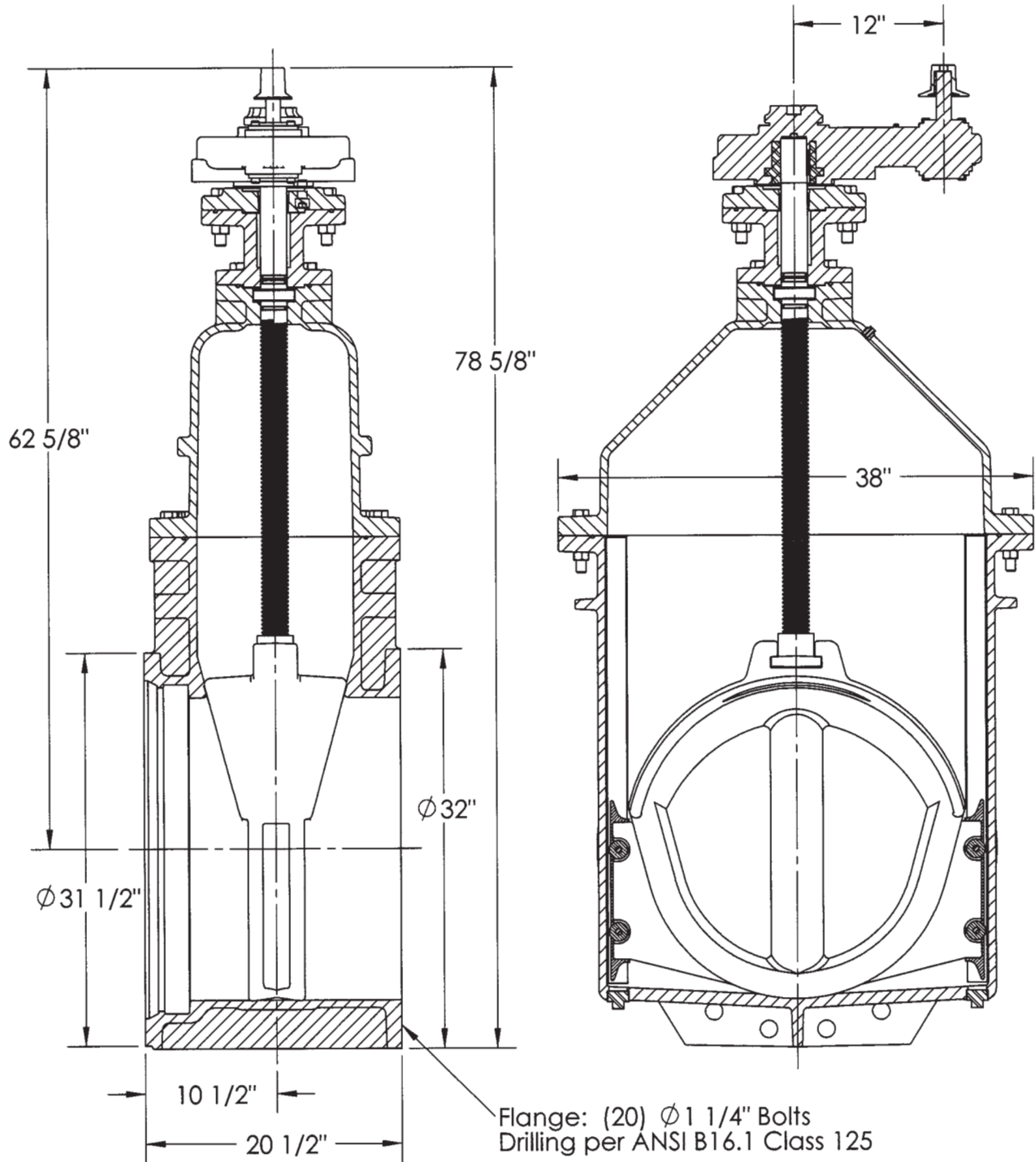

2638-94
E 10/10

Complies with applicable
requirements of AWWA C515

24" R/W RTS Spur Gear MJ x Tap
General Dimensions

CLOW VALVE COMPANY

MODEL 2638

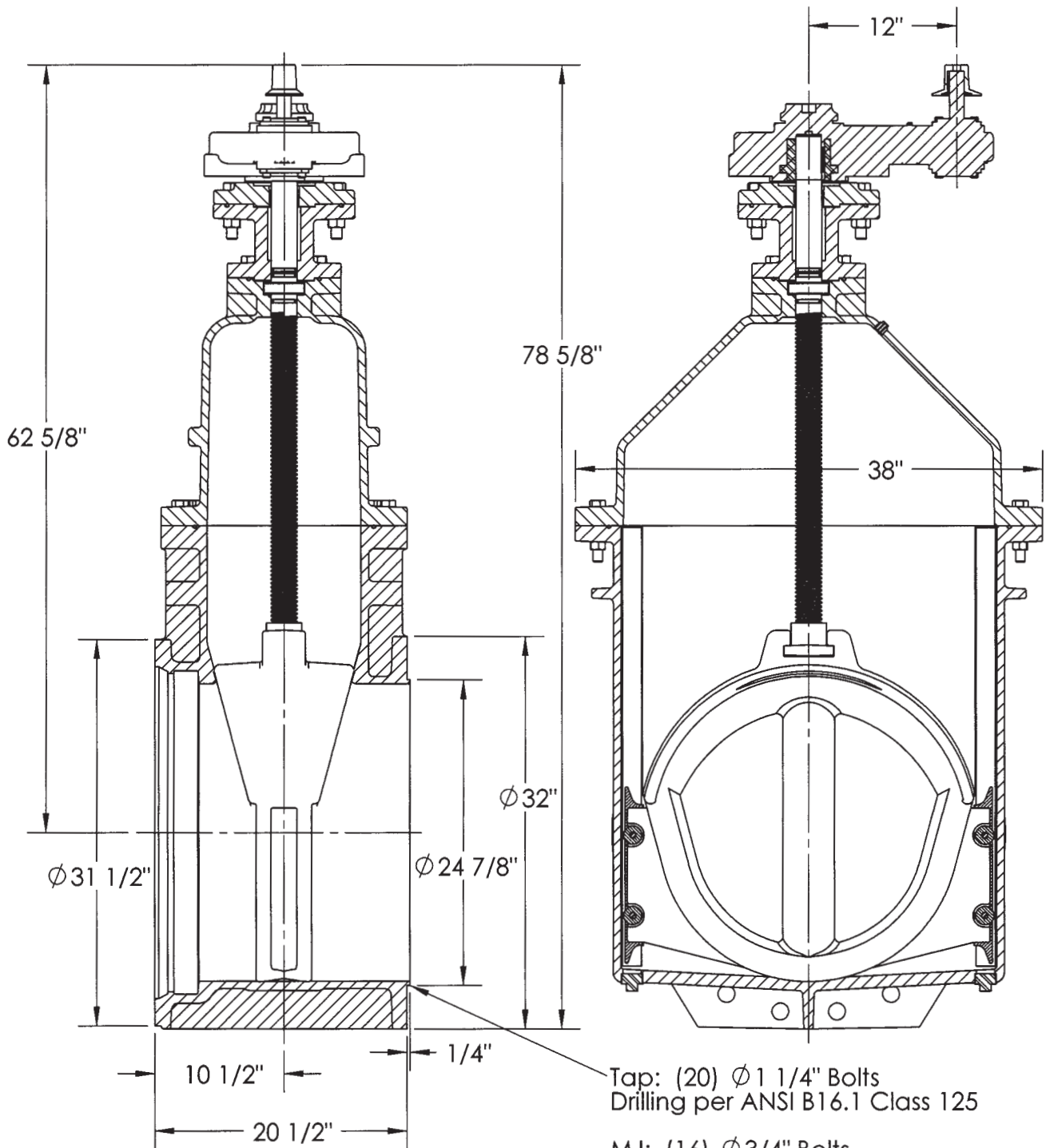

Tap: (20) $\phi 1\ 1/4"$ Bolts
Drilling per ANSI B16.1 Class 125

MJ: (16) $\phi 3/4"$ Bolts
Drilling per ANSI/AWWA C111/A21.11

Accommodates a full size diameter cutter

2638-100 Cat
E 10/10

Complies with applicable
requirements of AWWA C515

24" R/W OS&Y RTS BEVEL GEAR FLANGE END
PARTS LIST

CLOW VALVE COMPANY

MODEL 2638

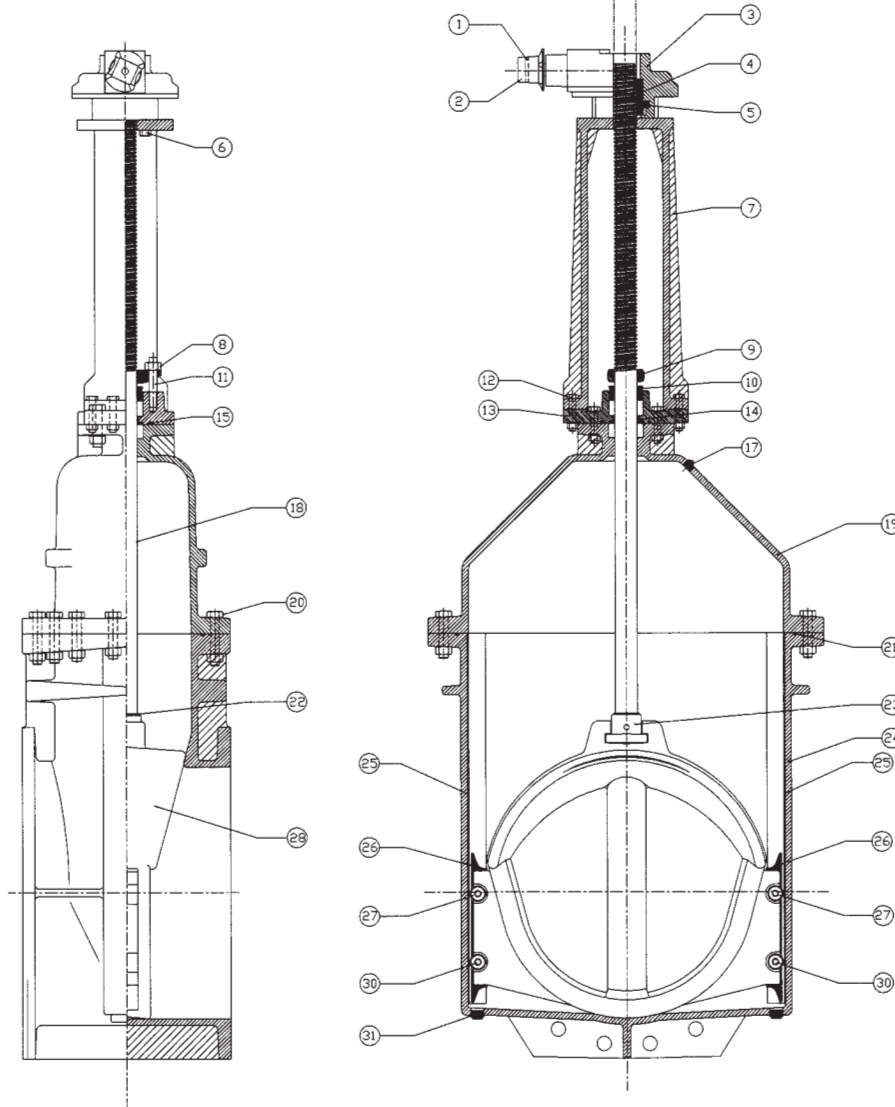

ITEM #	DESCRIPTION	MATERIAL	ITEM #	DESCRIPTION	MATERIAL
1	Roll Pin	Stainless Steel	17	Pipe Plug	Stainless Steel
2	Operating Nut	Gray Iron	18	Stem	Copper Alloy
3	Exeeco IB7 3-1	-	19	Cover	Ductile Iron
4	Square Key	Steel	20	Hex Bolt & Nut	Stainless Steel
5	Output Sleeve	Copper Alloy	21	Cover O-ring	Rubber
6	Hex Capscrew	Stainless Steel	22	Stem O-ring	Rubber
7	Yoke	Gray Iron	23	Stem Nut	Copper Alloy
8	Hex Nut	Copper Alloy	24	Body	Ductile Iron
9	Follower	Gray Iron	25	Track	Stainless Steel
10	Gland	Copper Alloy	26	Scraper	Copper Alloy
11	Stud	Stainless Steel	27	Roller	Copper Alloy
12	Hex Bolt & Nut	Stainless Steel	28	Wedge	Ductile Iron/EPDM
13	Adapter	Gray Iron	30	Pin	Stainless Steel
14	Bushing	Copper Alloy	31	Pipe Plug	Stainless Steel
15	O-ring	Rubber			

2638-101
C 10/10

Complies with applicable
requirements of AWWA C515

24" R/W OS&Y RTS BEVEL GEAR FLANGE END
GENERAL DIMENSIONS

CLOW VALVE COMPANY

MODEL 2638

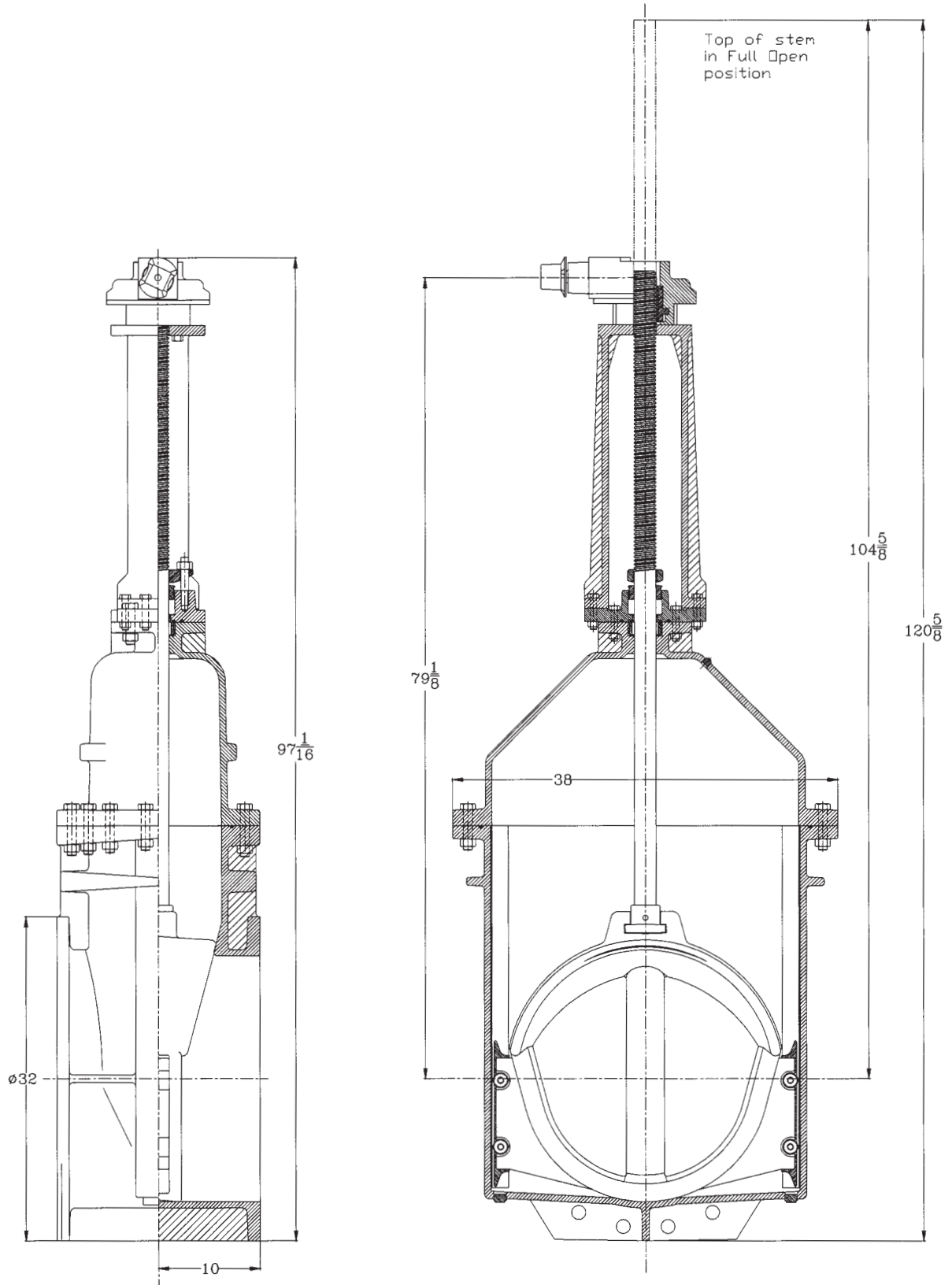

Complies with applicable
requirements of AWWA C515

24" R/W OS&Y RTS SPUR GEAR FLANGE END
PARTS LIST

CLOW VALVE COMPANY

MODEL 2638

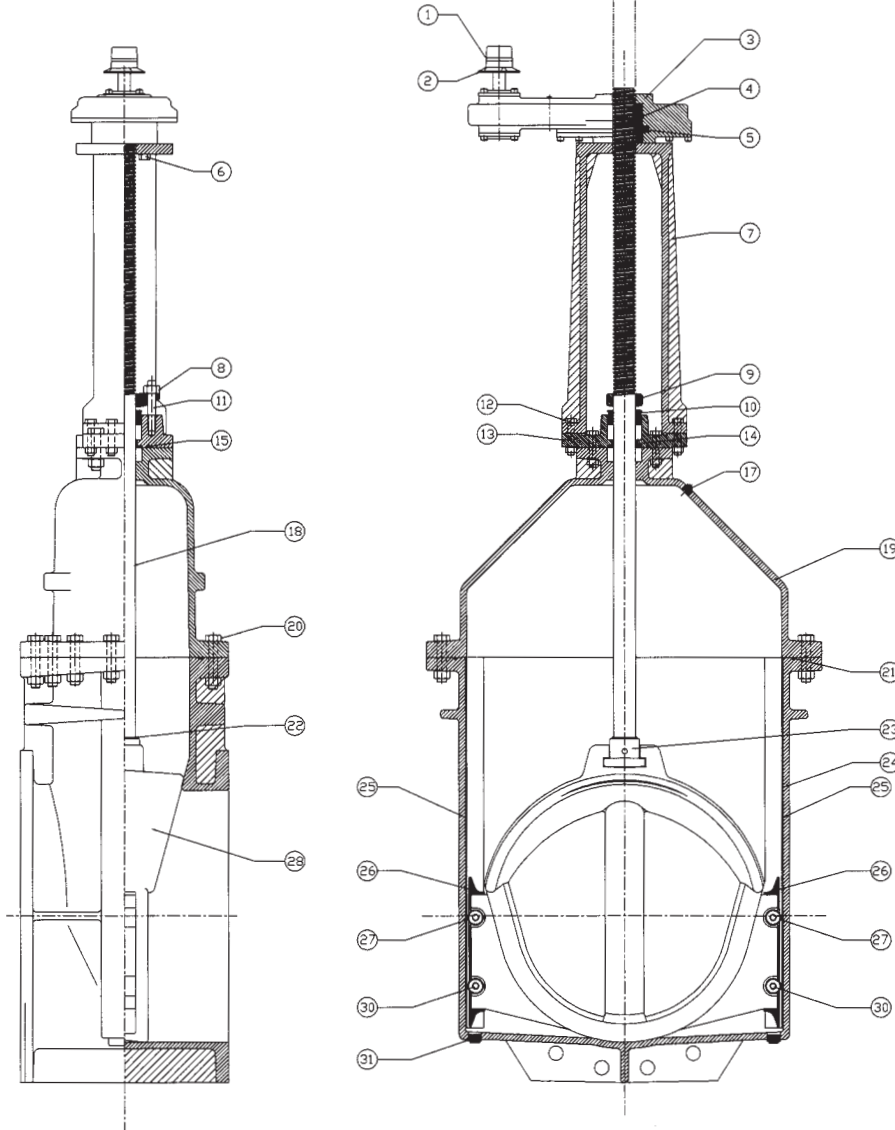

ITEM #	DESCRIPTION	MATERIAL	ITEM #	DESCRIPTION	MATERIAL
1	Roll Pin	Stainless Steel	17	Pipe Plug	Stainless Steel
2	Operating Nut	Gray Iron	18	Stem	Copper Alloy
3	Exeeco IS7 3/1	-	19	Cover	Ductile Iron
4	Square Key	Steel	20	Hex Bolt & Nut	Stainless Steel
5	Output Sleeve	Copper Alloy	21	Cover D-ring	Rubber
6	Hex Capscrew	Stainless Steel	22	Stem D-ring	Rubber
7	Yoke	Gray Iron	23	Stem Nut	Copper Alloy
8	Hex Nut	Copper Alloy	24	Body	Ductile Iron
9	Follower	Gray Iron	25	Track	Stainless Steel
10	Gland	Copper Alloy	26	Scraper	Copper Alloy
11	Stud	Stainless Steel	27	Roller	Copper Alloy
12	Hex Bolt & Nut	Stainless Steel	28	Wedge	Ductile Iron/EPDM
13	Adopter	Gray Iron	30	Pin	Stainless Steel
14	Bushing	Copper Alloy	31	Pipe Plug	Stainless Steel
15	O-ring	Rubber			

2638-103
C 10/10

Complies with applicable
requirements of AWWA C515

24" R/W OS&Y RTS SPUR GEAR FLANGE END
GENERAL DIMENSIONS

CLOW VALVE COMPANY

MODEL 2638

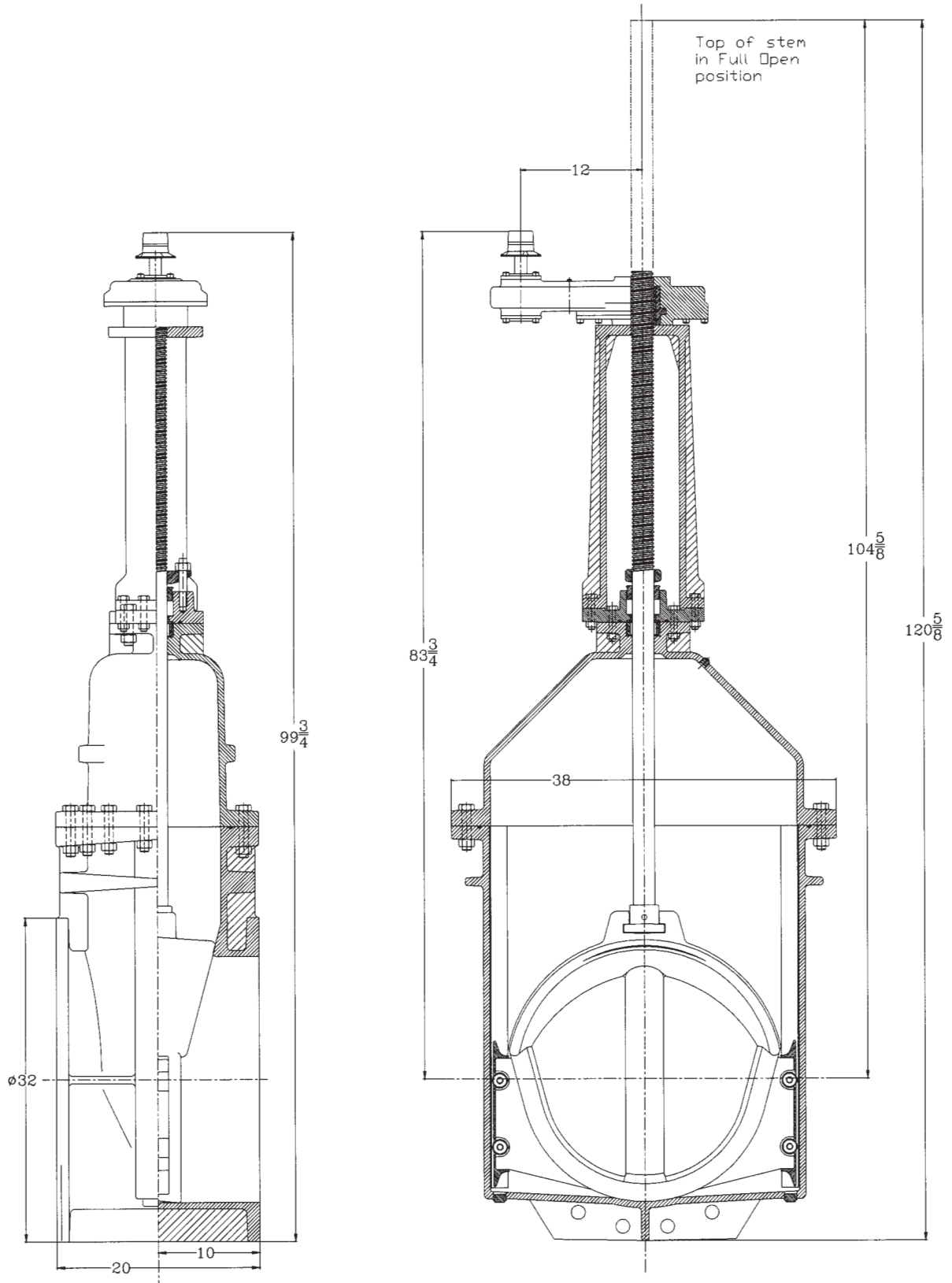

Complies with applicable
requirements of AWWA C515

30"-54" R/W VALVE
BEVEL GEAR ASSEMBLY
CLOW VALVE COMPANY

MODEL 2638

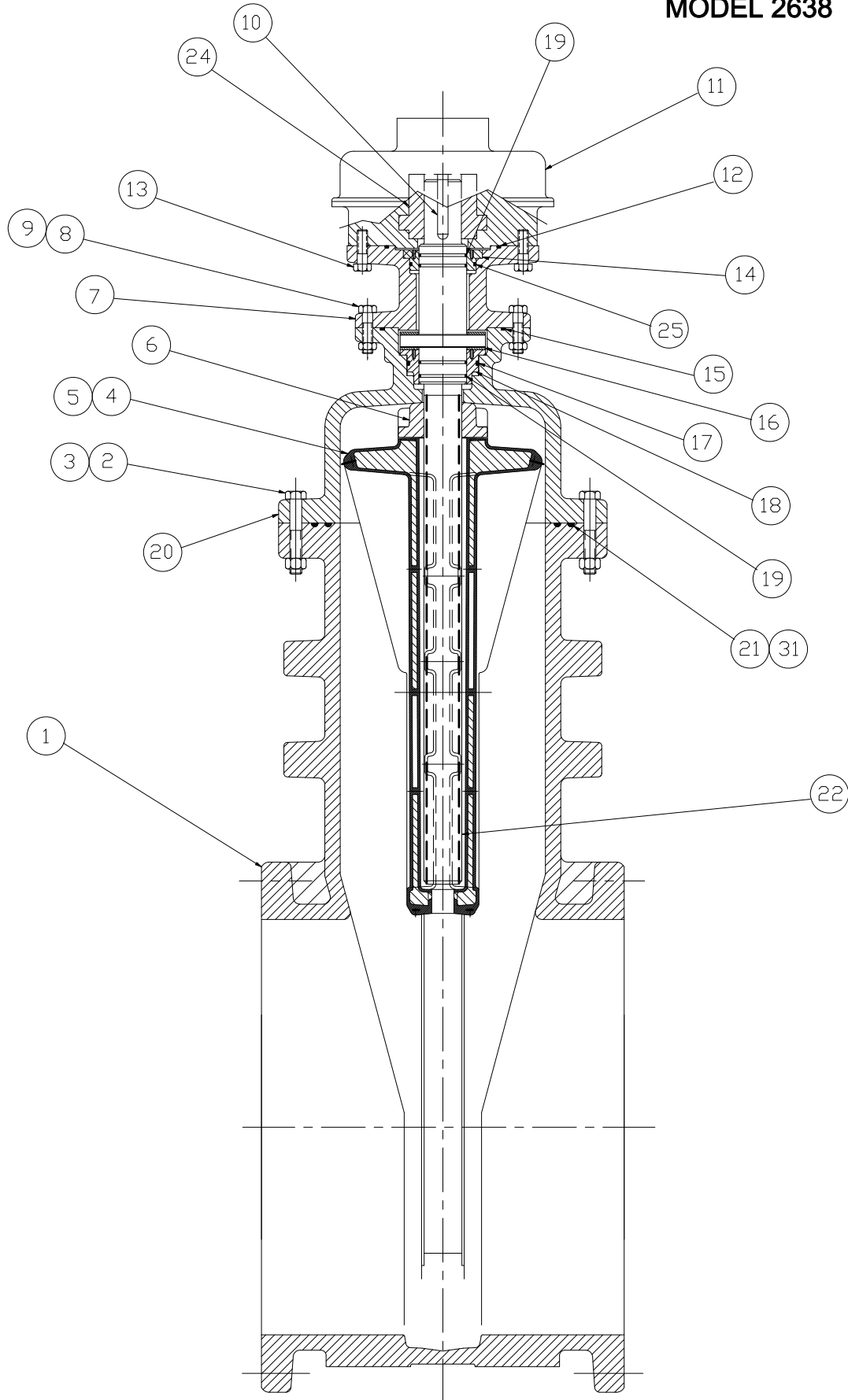

Complies with applicable
requirements of AWWA C515

30"-54" R/W VALVE
BEVEL GEAR ASSEMBLY
CLOW VALVE COMPANY

MODEL 2638

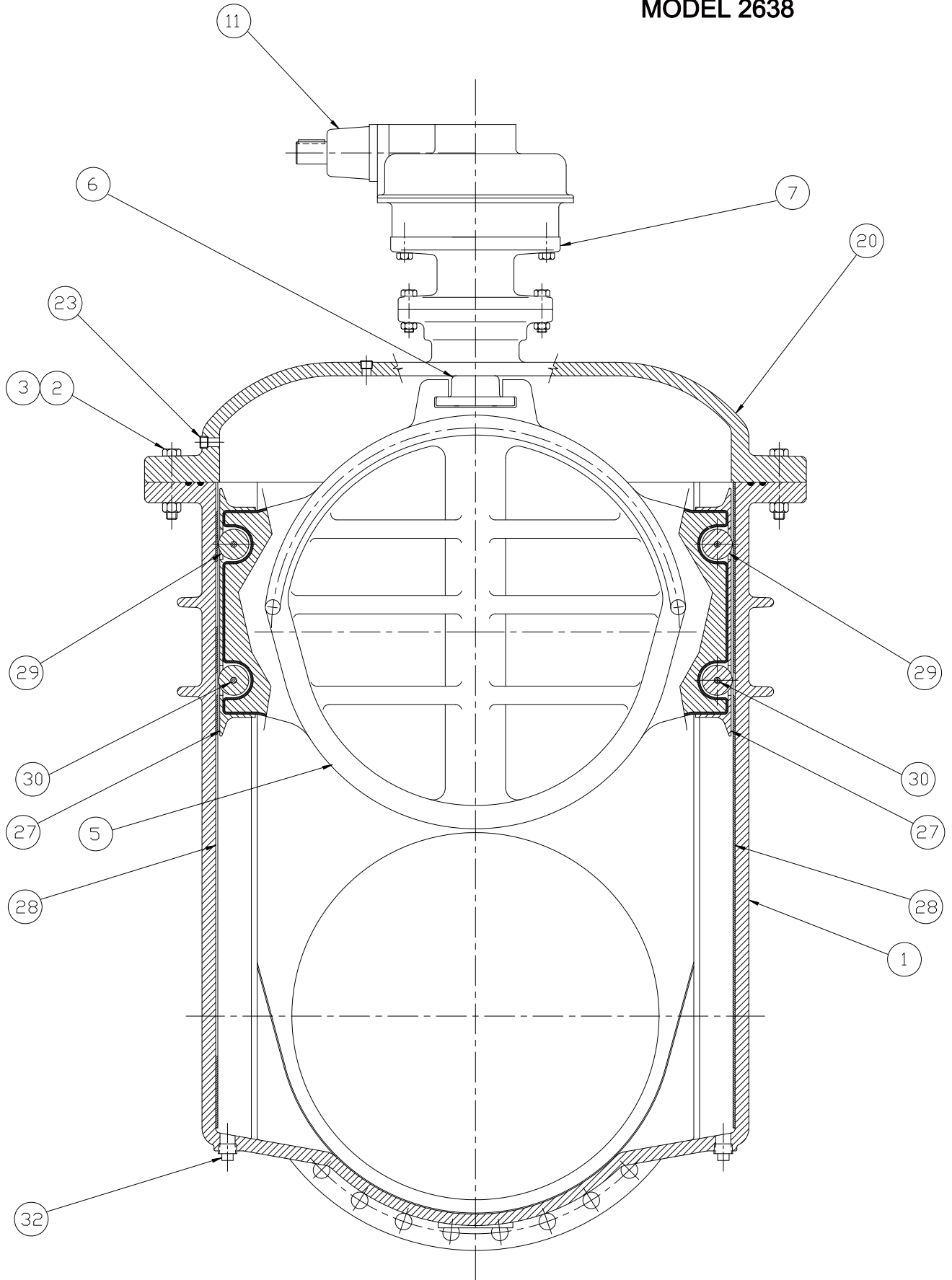

Complies with applicable
requirements of AWWA C515

30"-54" R/W VALVE
BEVEL GEAR PARTS LIST
CLOW VALVE COMPANY
MODEL 2638

Item	Description	Material
1	Body - Mechanical Joint	Ductile iron
	Body - Flange	Ductile iron
	Body - MJ x Flange	Ductile iron
2	Bolt	Stainless Steel
3	Nut	Stainless Steel
4	Wedge Casting	Ductile iron
5	Molded Wedge	Rubber
6	Stem Nut	Copper Alloy
7	Extension - actuator	Ductile iron
8	Bolt	Stainless Steel
9	Nut	Stainless Steel
10	Key	Steel
11	Actuator - bevel gear	-
12	□-ring	Rubber
13	Bolt	Stainless Steel
14	Bushing - stem guide	Copper Alloy
15	□-ring	Rubber
16	Thrust Bearing	Nylatron
17	□-ring	Rubber
18	Cover Bushing	Copper Alloy
19	□-ring	Rubber
20	Cover	Ductile iron
21	□-ring - cover outer	Rubber
22	Stem	Copper Alloy
23	Pipe Plug	Stainless Steel
24	Actuator Drive Bushing	Steel
25	□-ring	Rubber
27	Scraper	Copper Alloy
28	Track	Stainless Steel
29	Roller	Copper Alloy
30	Pin - roller	Stainless Steel
31	□-ring - cover inner	Rubber
32	Pipe Plug	Stainless Steel

2638-53
F 1/11

Complies with applicable
requirements of AWWA C515

30"-54" R/W VALVE FLANGED ENDS
BEVEL GEAR GENERAL DIMENSIONS

CLOW VALVE COMPANY

MODEL 2638

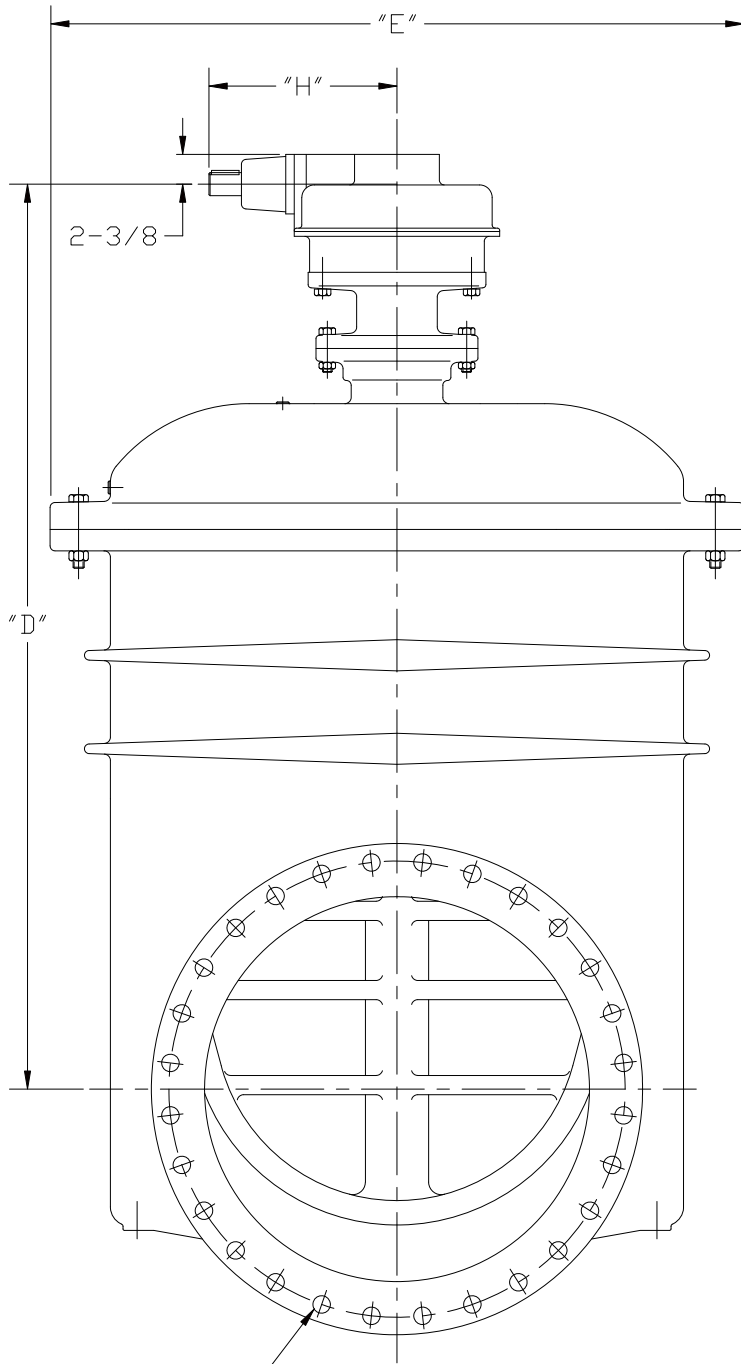

ANSI B16.1 Class 125 Drilling
for "F" # & "G" Size Bolts

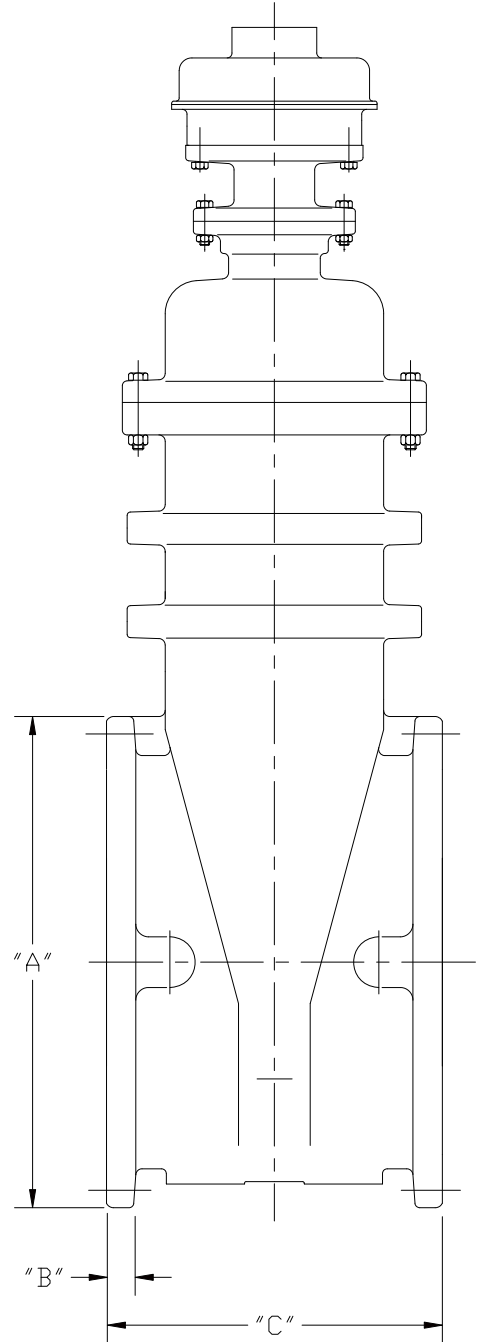

Valve Size	"A"	"B"	"C"	"D"	"E"	"F"	"G"	"H"
30"	38-3/4	2-1/8	26-1/2	71-3/8	54-3/4	28	1-1/4	14-7/8
36"	46	2-3/8	30-3/4	81-1/16	58-7/8	32	1-1/2	14-7/8
42"	53	2-5/8	36	98-3/8	78	36	1-1/2	17
48"	59-1/2	2-3/4	35-1/2	101-3/8	78	44	1-1/2	17
54"	66-1/4	3	48	101-3/8	78	44	1-3/4	17

2638-54
F 10/10

Complies with applicable
requirements of AWWA C515

30"-48" R/W VALVE MECH. JOINT ENDS
BEVEL GEAR GENERAL DIMENSIONS

CLOW VALVE COMPANY

MODEL 2638

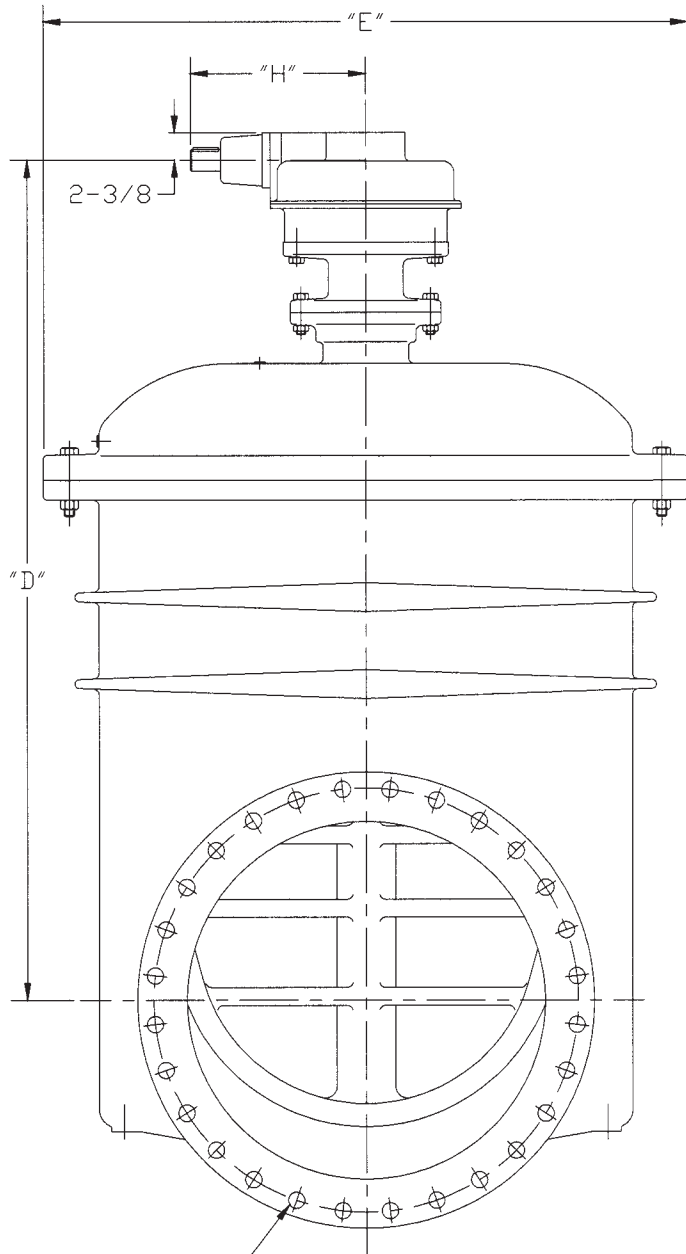

ANSI/AWWA C111/A21.11 Drilling
for "F" # & "G" Size Bolts

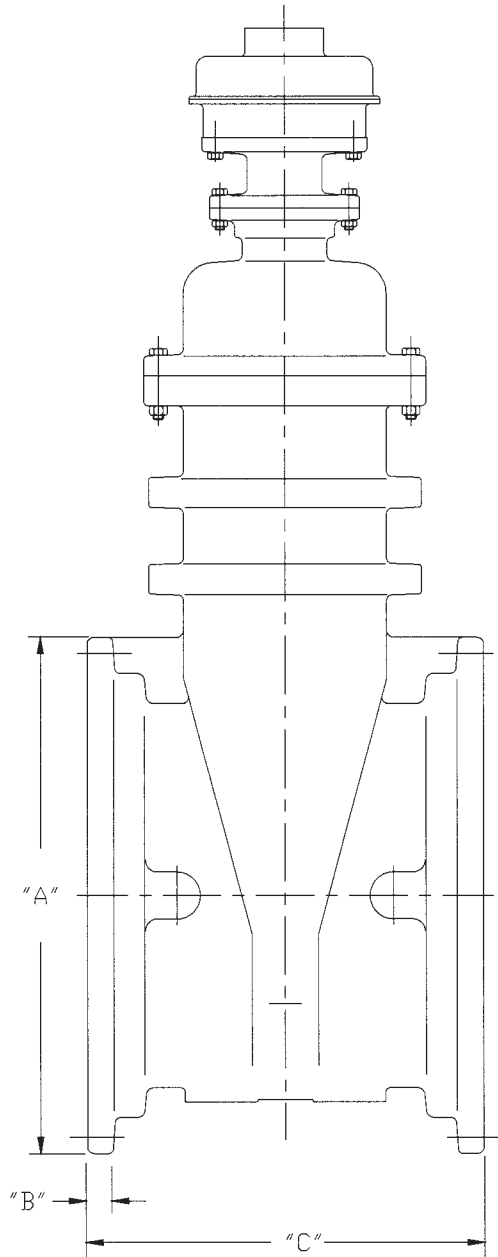

Valve Size	"A"	"B"	"C"	"D"	"E"	"F"	"G"	"H"
30"	39-1/2	1-11/16	35-1/2	71-3/8	54-3/4	20	1"	14-7/8
36"	46-1/2	2	38-3/4	81-1/16	58-7/8	24	1"	14-7/8
42"	54	2	39	98-3/8	78	28	1-1/4	17
48"	60-3/4	2	42	101-3/8	78	32	1-1/4	17

2638-55
F 10/10

Complies with applicable
requirements of AWWA C515

30"-48" R/W VALVE MJ x FLG ENDS BEVEL
GEAR GENERAL DIMENSIONS

CLOW VALVE COMPANY

MODEL 2638

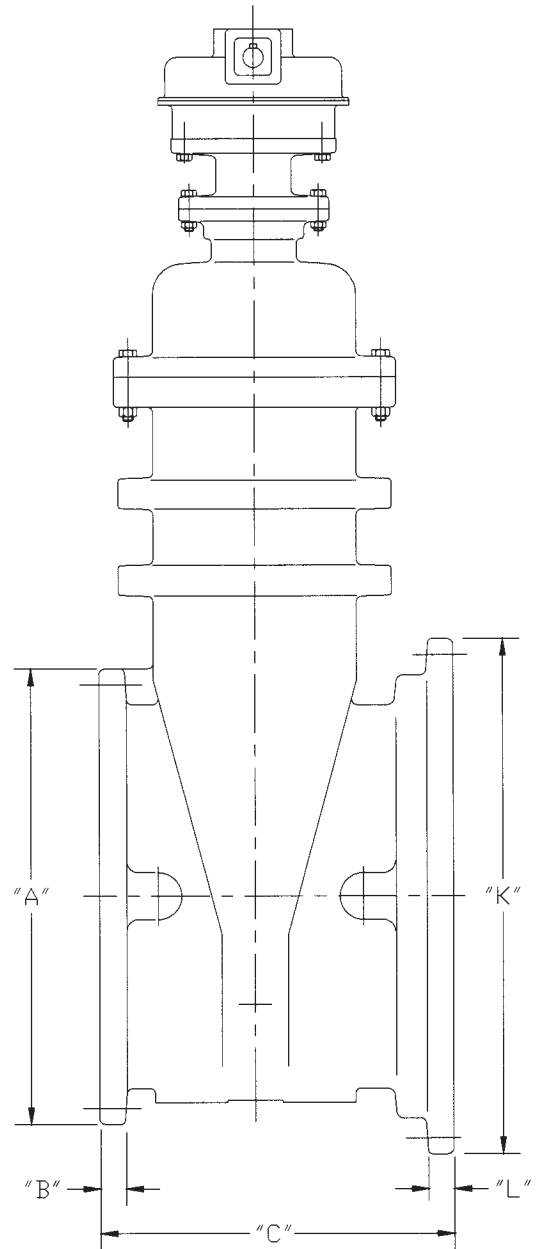
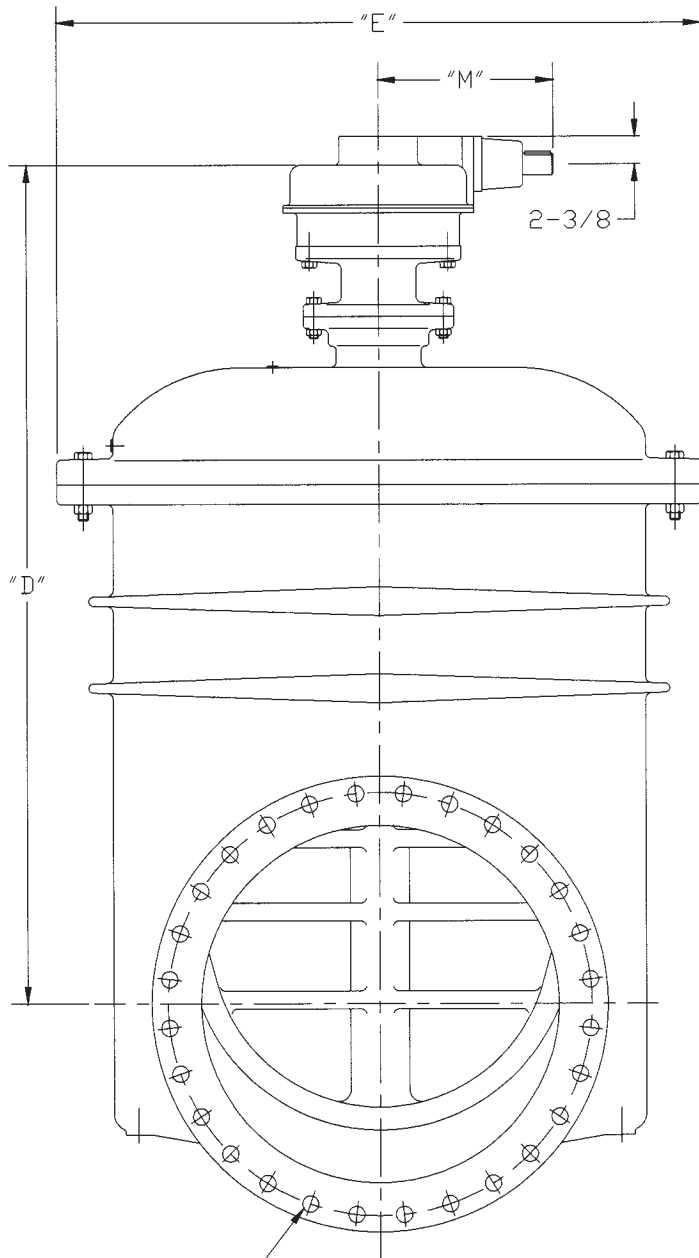

Flange End: ANSI B16.1 Class 125
Drilling for "F" # & "G" Size Bolts
MJ End: ANSI/AWWA C111/A21.11
Drilling for "H" # & "J" Size Bolts

Valve Size	"A"	"B"	"C"	"D"	"E"	"F"	"G"	"H"	"J"	"K"	"L"	"M"
30"	38-3/4	2-1/8	31	71-3/8	54-3/4	28	1-1/4	20	1"	39-1/2	1-11/16	14-7/8
36"	46	2-3/8	34-3/4	81-1/16	58-7/8	32	1-1/2	24	1"	46-1/2	2	14-7/8
42"	53	2-5/8	37-1/2	98-3/8	78	36	1-1/2	28	1-1/4	54	2	17
48"	59-1/2	2-3/4	39	101-3/8	78	44	1-1/2	32	1-1/4	60-3/4	2	17

Complies with applicable
requirements of AWWA C515

30"-54" R/W VALVE
SPUR GEAR ASSEMBLY
CLOW VALVE COMPANY

MODEL 2638

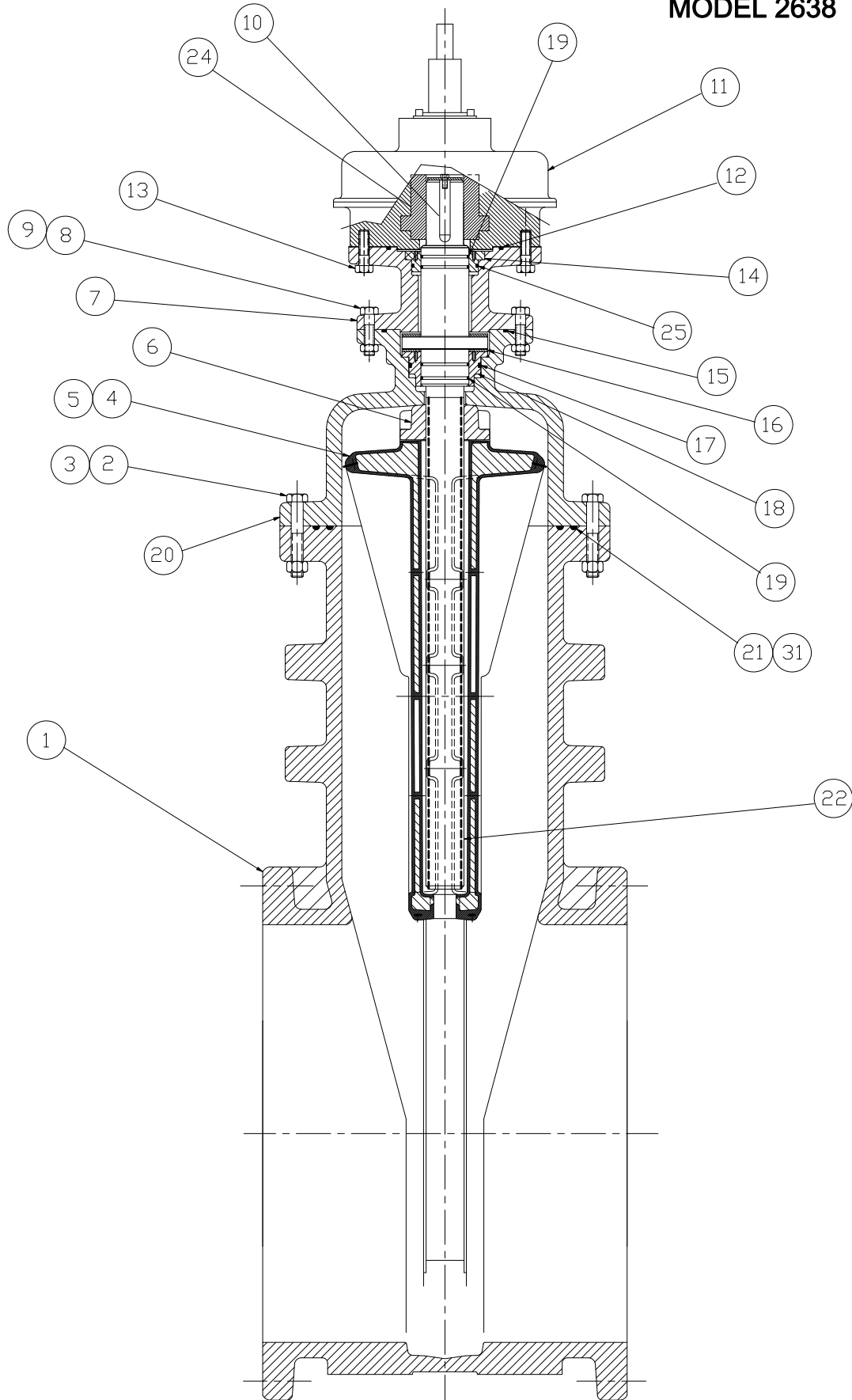

Complies with applicable
requirements of AWWA C515

30"-54" R/W VALVE
SPUR GEAR ASSEMBLY
CLOW VALVE COMPANY

MODEL 2638

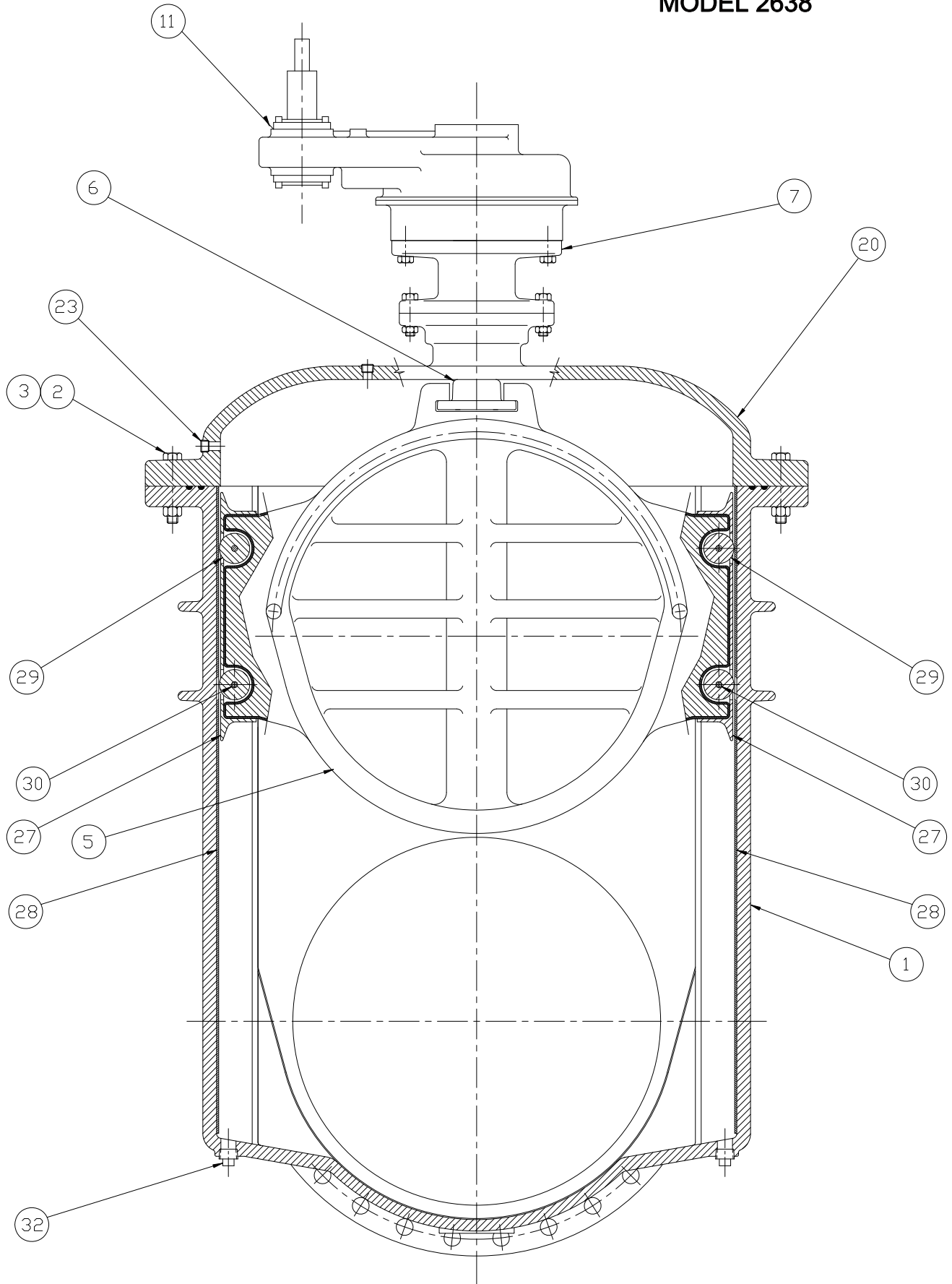

Complies with applicable
requirements of AWWA C515

30"-54" R/W VALVE
SPUR GEAR PARTS LIST
CLOW VALVE COMPANY
MODEL 2638

Item	Description	Material
1	Body - Mechanical Joint	Ductile iron
	Body - Flange	Ductile iron
	Body - MJ x Flange	Ductile iron
2	Bolt	Stainless Steel
3	Nut	Stainless Steel
4	Wedge Casting	Ductile iron
5	Molded Wedge	Rubber
6	Stem Nut	Copper Alloy
7	Extension - actuator	Ductile iron
8	Bolt	Stainless Steel
9	Nut	Stainless Steel
10	Key	Steel
11	Actuator - spur gear	-
12	□-ring	Rubber
13	Bolt	Stainless Steel
14	Bushing - stem guide	Copper Alloy
15	□-ring	Rubber
16	Thrust Bearing	Nylatron
17	□-ring	Rubber
18	Cover Bushing	Copper Alloy
19	□-ring	Rubber
20	Cover	Ductile iron
21	□-ring - cover outer	Rubber
22	Stem	Copper Alloy
23	Pipe Plug	Stainless Steel
24	Actuator Drive Bushing	Steel
25	□-ring	Rubber
27	Scraper	Copper Alloy
28	Track	Stainless Steel
29	Roller	Copper Alloy
30	Pin - roller	Stainless Steel
31	□-ring - cover inner	Rubber
32	Pipe Plug	Stainless Steel

Complies with applicable requirements of AWWA C515

30"-54" R/W VALVE FLANGED ENDS
SPUR GEAR GENERAL DIMENSIONS

CLOW VALVE COMPANY

MODEL 2638

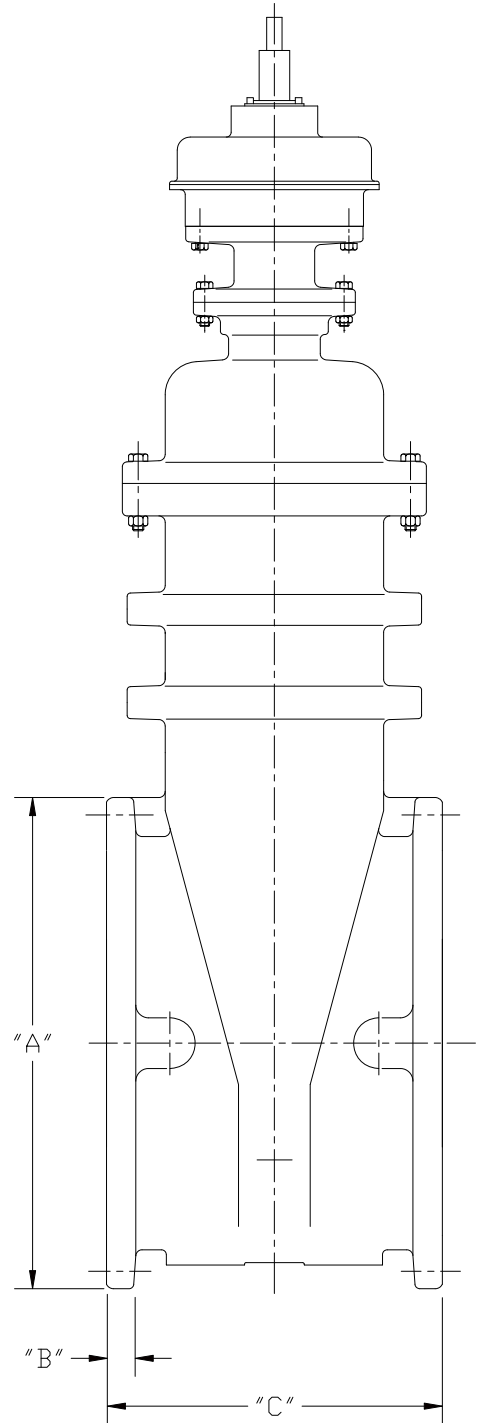
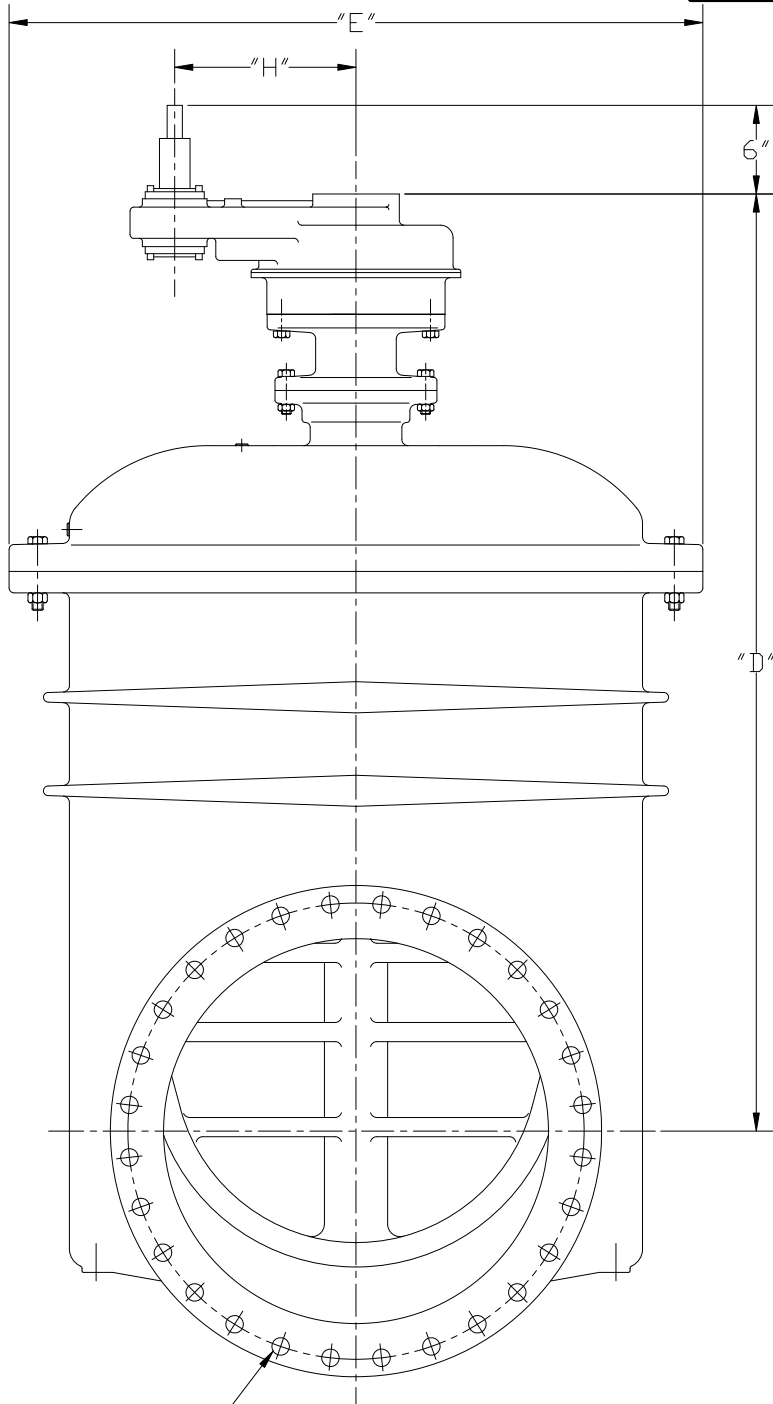

ANSI B16.1 Class 125 Drilling for "F" # & "G" Size Bolts

Valve Size	"A"	"B"	"C"	"D"	"E"	"F"	"G"	"H"
30"	38-3/4	2-1/8	26-1/2	74	54-3/4	28	1-1/4	14
36"	46	2-3/8	30-3/4	83-11/16	58-7/8	32	1-1/2	14
42"	53	2-5/8	36	102-1/2	78	36	1-1/2	16
48"	59-1/2	2-3/4	35-1/2	105-1/2	78	44	1-1/2	16
54"	66-1/4	3	48	105-1/2	78	44	1-3/4	16

2638-61
E 10/10

Complies with applicable requirements of AWWA C515

30"-48" R/W VALVE MECH. JOINT ENDS
SPUR GEAR GENERAL DIMENSIONS

CLOW VALVE COMPANY

MODEL 2638

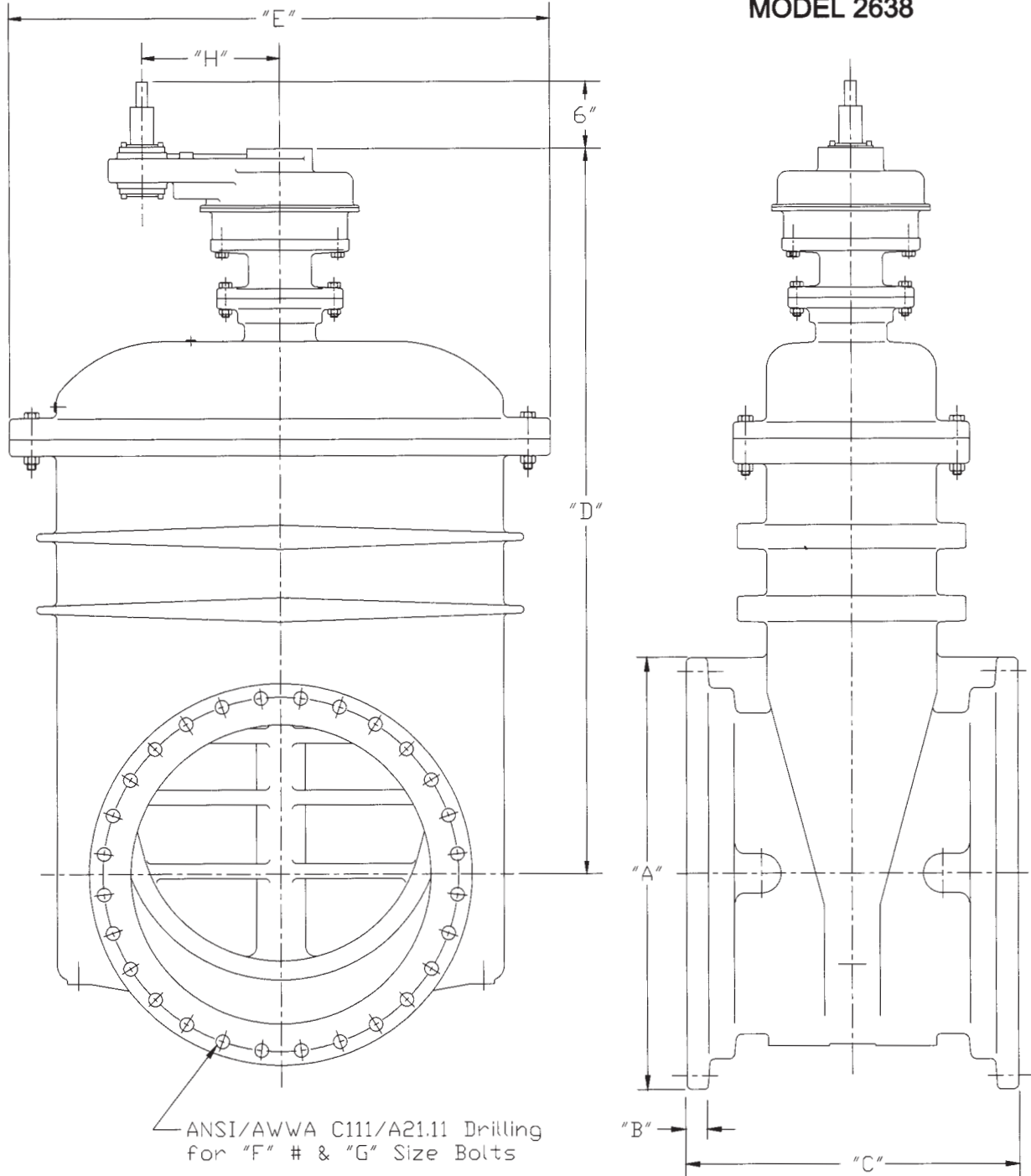

Valve Size	"A"	"B"	"C"	"D"	"E"	"F"	"G"	"H"
30"	39-1/2	1-11/16	35-1/2	74	54-3/4	20	1"	14
36"	46-1/2	2	38-3/4	83-11/16	58-7/8	24	1"	14
42"	54	2	39	102-1/2	78	28	1-1/4	16
48"	60-3/4	2	42	105-1/2	78	32	1-1/4	16

2638-62
E 10/10

Complies with applicable
requirements of AWWA C515

30"-48" RW VALVE MJ x FLG ENDS SPUR
GEAR GENERAL DIMENSIONS

CLOW VALVE COMPANY

MODEL 2638

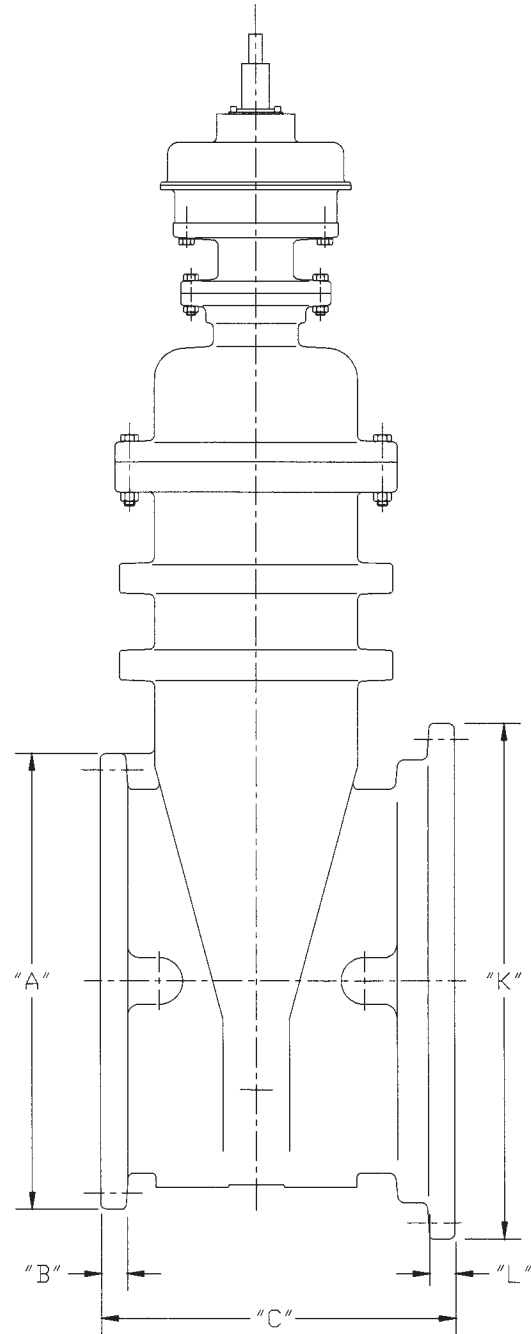
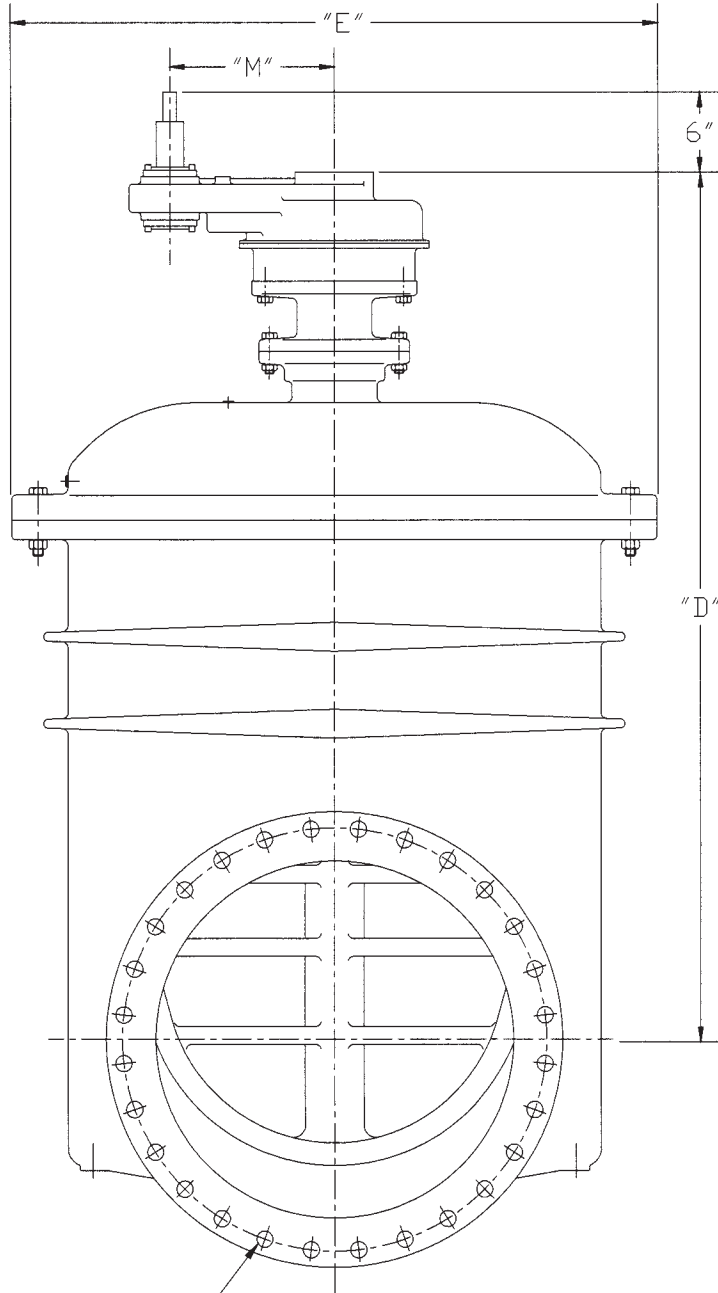

Flange End: ANSI B16.1 Class 125
Drilling for "F" # & "G" Size Bolts
MJ End: ANSI/AWWA C111/A21.11
Drilling for "H" # & "J" Size Bolts

Valve Size	"A"	"B"	"C"	"D"	"E"	"F"	"G"	"H"	"J"	"K"	"L"	"M"
30"	38-3/4	2-1/8	31	74	54-3/4	28	1-1/4	20	1"	39-1/2	1-11/16	14
36"	46	2-3/8	34-3/4	83-11/16	58-7/8	32	1-1/2	24	1"	46-1/2	2	14
42"	53	2-5/8	37-1/2	102-1/2	78	36	1-1/2	28	1-1/4	54	2	16
48"	59-1/2	2-3/4	39	105-1/2	78	44	1-1/2	32	1-1/4	60-3/4	2	16

2638-64
B 10/28/10

Complies with applicable
requirements of AWWA C515

30"-48" RW VALVE BEVEL GEAR
ASSEMBLY WITH BYPASS

CLOW VALVE COMPANY

MODEL 2638

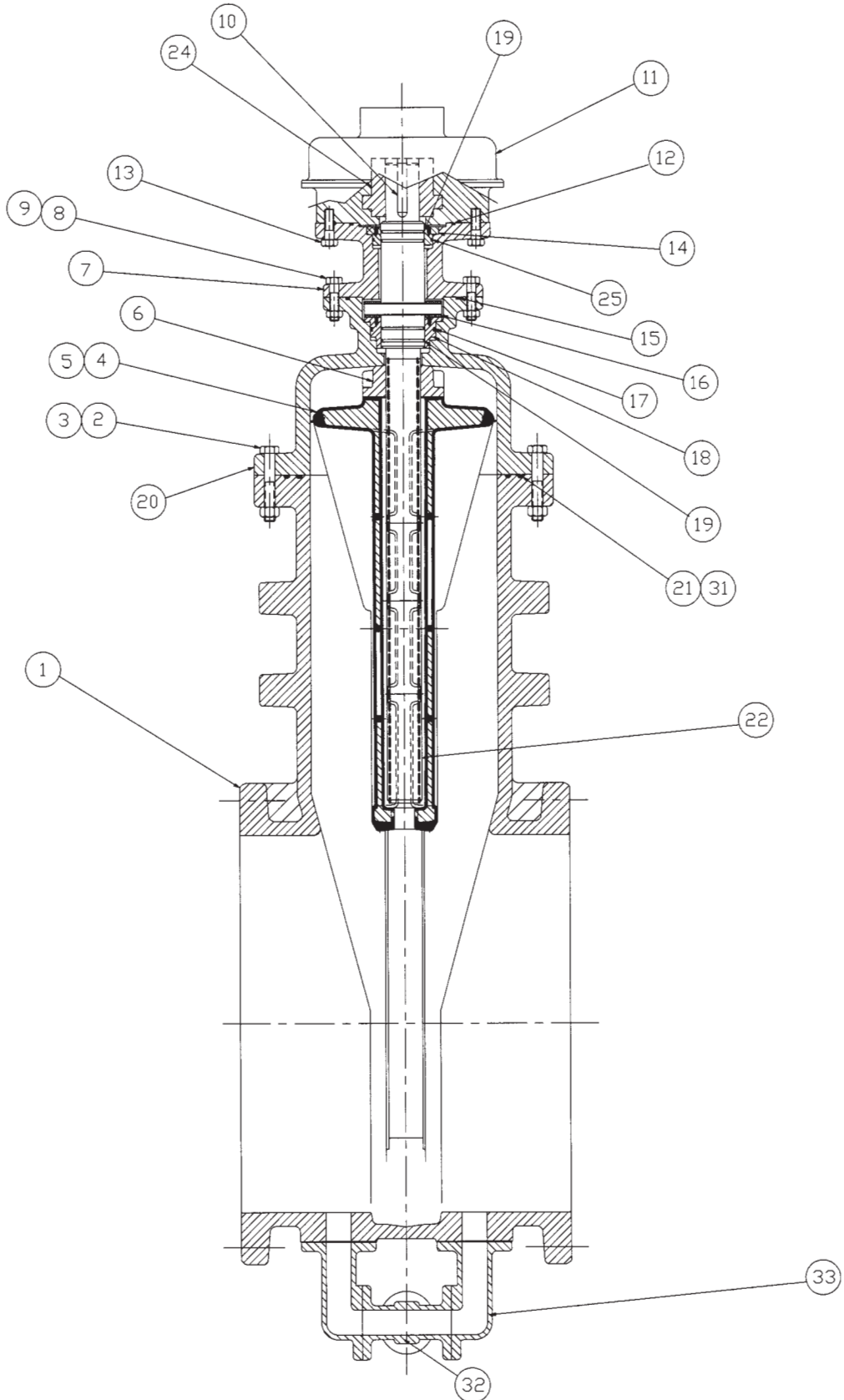

2638-65
E 10/10

Complies with applicable
requirements of AWWA C515

30"-48" R/W VALVE BEVEL GEAR
ASSEMBLY WITH BYPASS

CLOW VALVE COMPANY

MODEL 2638

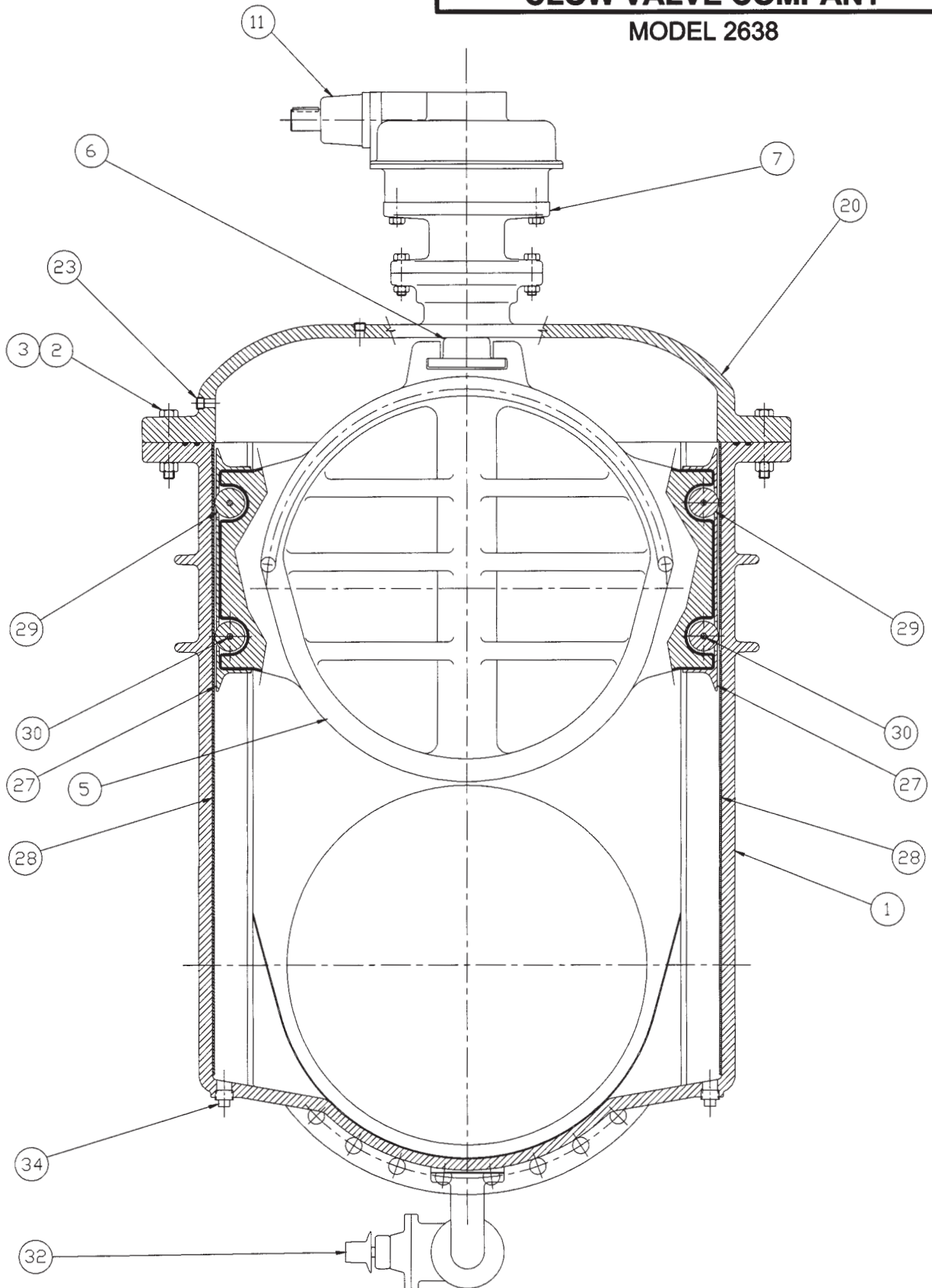

Complies with applicable
requirements of AWWA C515

30"-48" R/W VALVE BEVEL GEAR
PARTS LIST WITH BYPASS

CLOW VALVE COMPANY

MODEL 2638

Item	Description	Material
1	Body - Mechanical Joint	Ductile iron
	Body - Flange	Ductile iron
	Body - MJ x Flange	Ductile iron
2	Bolt	Stainless Steel
3	Nut	Stainless Steel
4	Wedge Casting	Ductile iron
5	Molded Wedge	Rubber
6	Stem Nut	Copper Alloy
7	Extension - actuator	Ductile iron
8	Bolt	Stainless Steel
9	Nut	Stainless Steel
10	Key	Steel
11	Actuator - bevel gear	-
12	O-ring	Rubber
13	Bolt	Stainless Steel
14	Bushing - stem guide	Copper Alloy
15	O-ring	Rubber
16	Thrust Bearing	Nylatron
17	O-ring	Rubber
18	Cover Bushing	Copper Alloy
19	O-ring	Rubber
20	Cover	Ductile iron
21	O-ring - cover outer	Rubber
22	Stem	Copper Alloy
23	Pipe Plug	Stainless Steel
24	Actuator Drive Bushing	Steel
25	O-ring	Rubber
27	Scraper	Copper Alloy
28	Track	Stainless Steel
29	Roller	Copper Alloy
30	Pin - roller	Stainless Steel
31	O-ring - cover inner	Rubber
32	Bypass Valve	Ductile iron
33	Bypass Elbow	Ductile iron
34	Pipe Plug	Stainless Steel

2638-67
D 10/10

Complies with applicable requirements of AWWA C515

30"-48" R/W VALVE FLANGED ENDS BEVEL GEAR BYPASS GENERAL DIMENSIONS

CLOW VALVE COMPANY

MODEL 2638

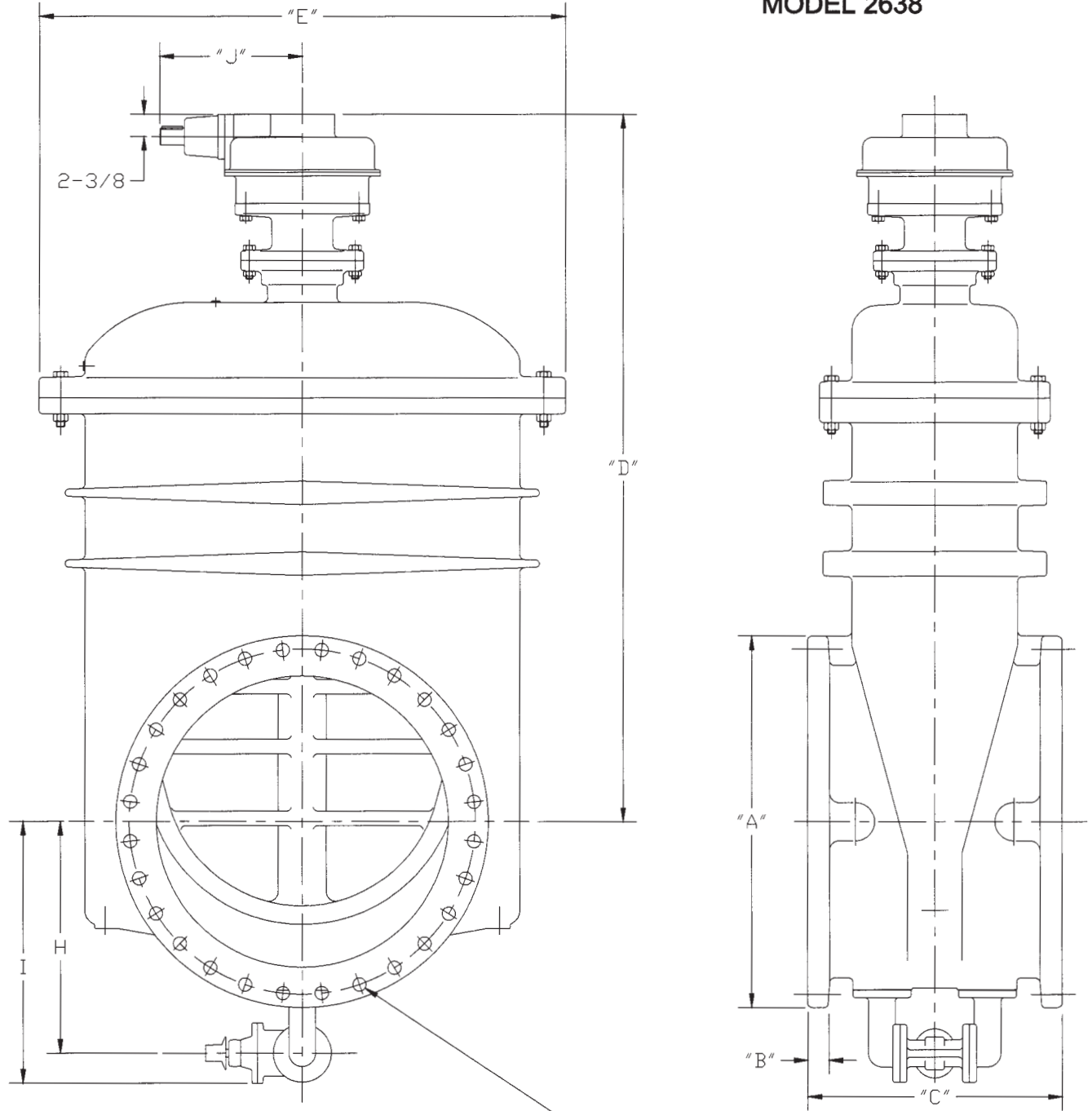

ANSI B16.1 Class 125 Drilling for "F" # & "G" Size Bolts

Valve Size	"A"	"B"	"C"	"D"	"E"	"F"	"G"	"H"	"I"	"J"
30"	38-3/4	2-1/8	26-1/2	73-3/4	54-3/4	28	1-1/4	24	27	14-7/8
36"	46	2-3/8	30-3/4	83-7/16	58-7/8	32	1-1/2	27-1/4	30-1/4	14-7/8
42"	53	2-5/8	36	100-3/4	78	36	1-1/2	30-15/16	35-7/16	17
48"	59-1/2	2-3/4	35-1/2	103-3/4	78	44	1-1/2	33-15/16	38-7/16	17

2638-68
G 04/13

Complies with applicable requirements of AWWA C515

30"-48" R/W VALVE MJ ENDS BEVEL
GEAR BYPASS GENERAL DIMENSIONS

CLOW VALVE COMPANY

MODEL 2638

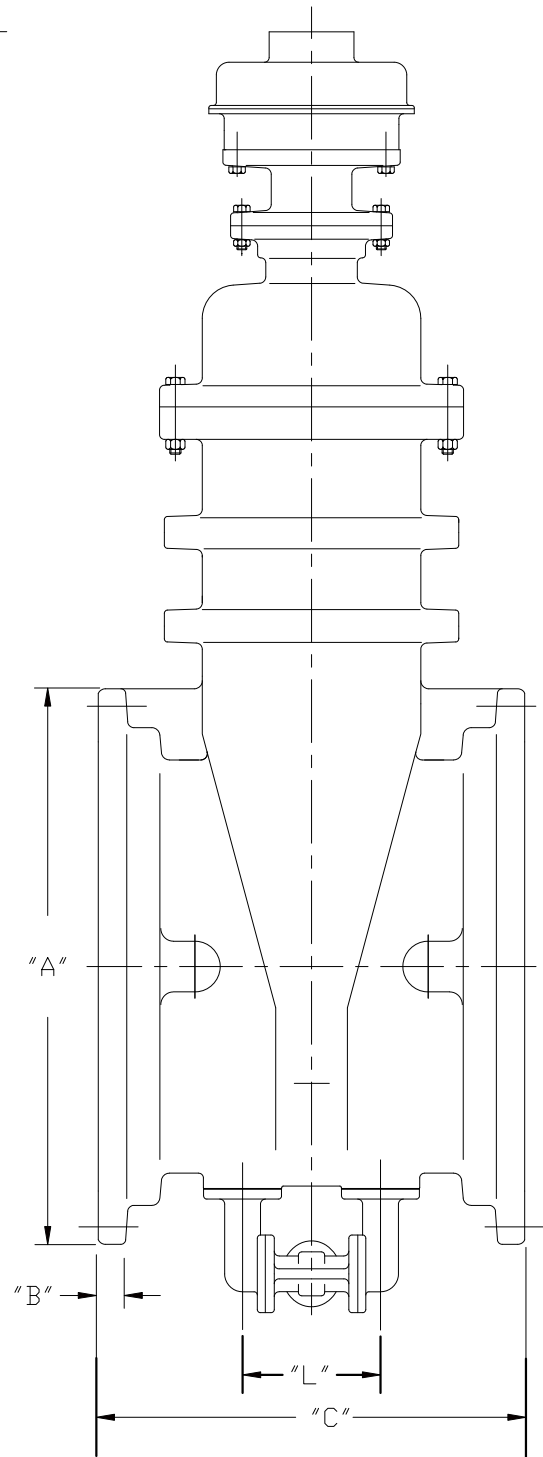
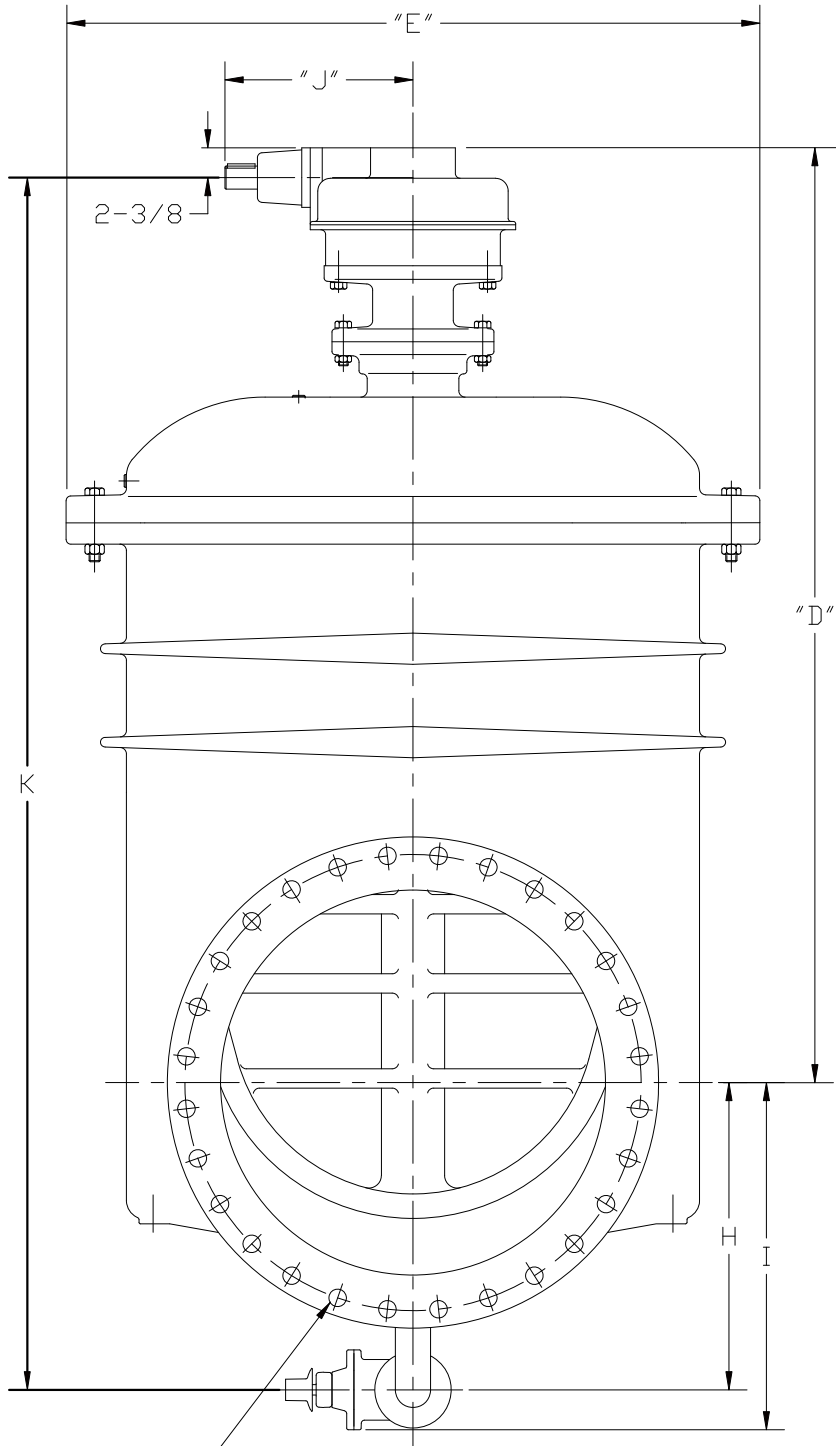

ANSI/AWWA C111/A21.11 Drilling for "F" # & "G" Size Bolts

Valve Size	"A"	"B"	"C"	"D"	"E"	"F"	"G"	"H"	"I"	"J"	"K"	"L"
30"	39-1/2	1-11/16	35-1/2	73-3/4	54-3/4	20	1"	24	27	14-7/8	95-3/8	10-7/8
36"	46-1/2	2	38-3/4	83-7/16	58-7/8	24	1"	27-1/4	30-1/4	14-7/8	108-5/16	10-7/8
42"	54	2	39	100-3/4	78	28	1-1/4	30-15/16	35-7/16	17	129-5/16	14-3/8
48"	60-3/4	2	42	103-3/4	78	32	1-1/4	33-15/16	38-7/16	17	135-5/16	14-3/8

2638-69
E 10/10

Complies with applicable requirements of AWWA C515

30"-48" R/W VALVE MJ x FLG ENDS BEVEL
GEAR BYPASS GENERAL DIMENSIONS

CLOW VALVE COMPANY

MODEL 2638

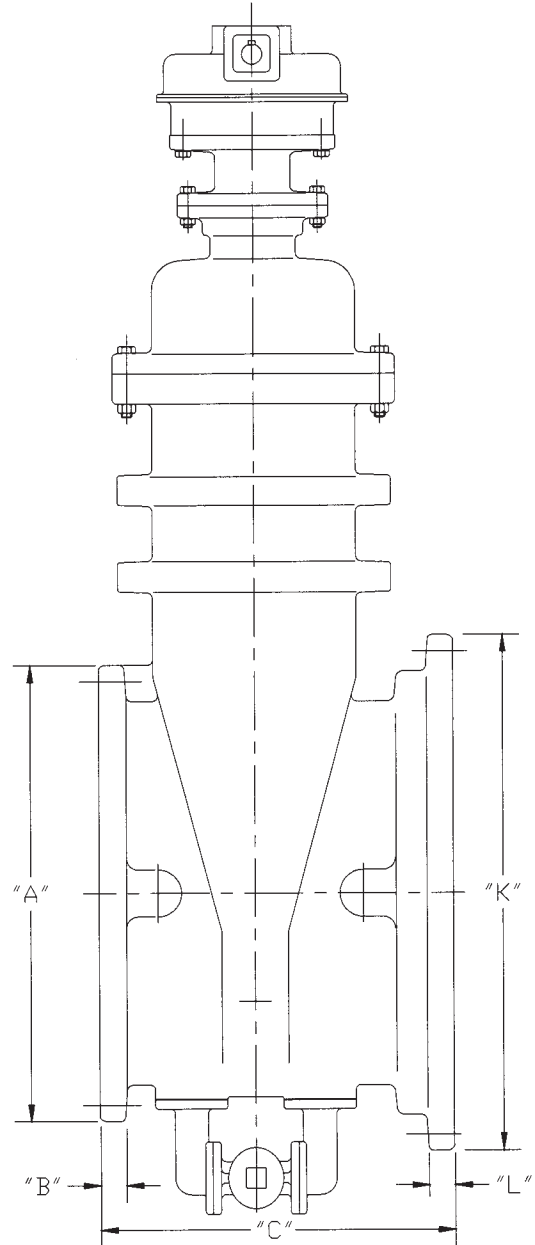
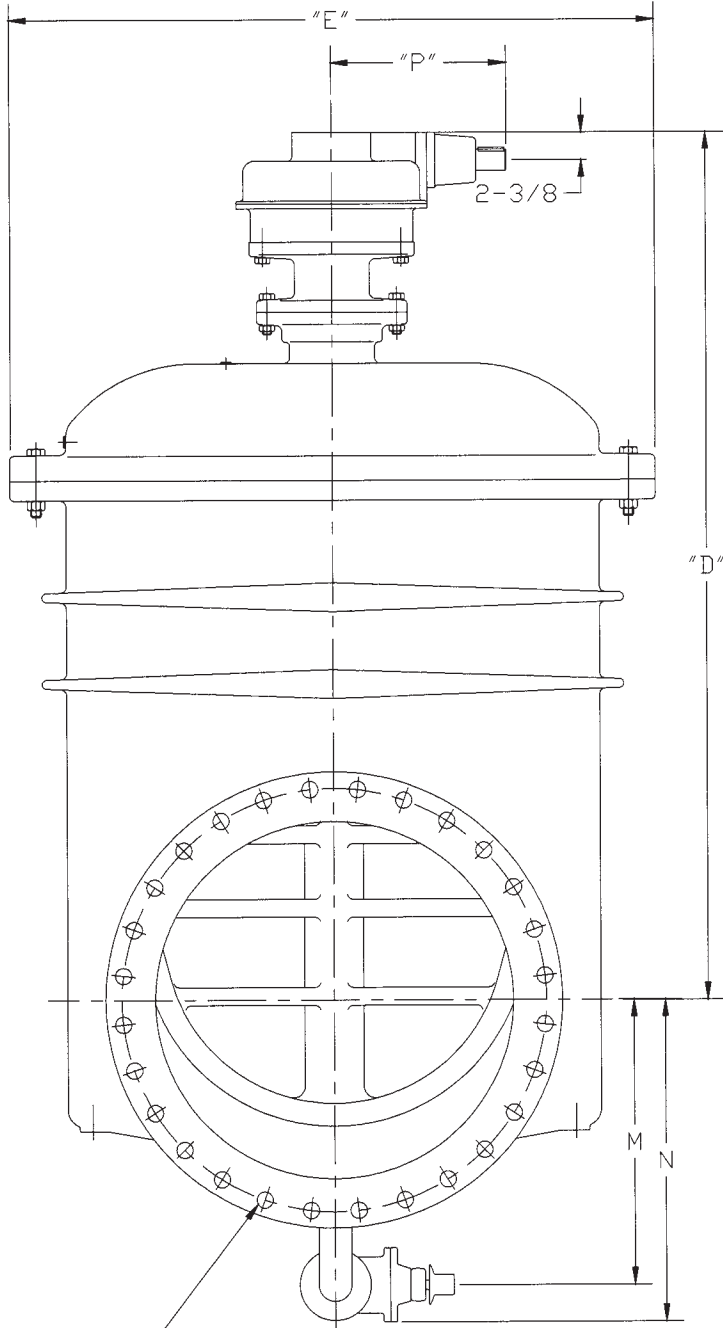

Flange End: ANSI B16.1 Class 125
Drilling for "F" # & "G" Size Bolts
MJ End: ANSI/AWWA C111/A21.11
Drilling for "H" # & "J" Size Bolts

V S	"A"	"B"	"C"	"D"	"E"	"F"	"G"	"H"	"J"	"K"	"L"	"M"	"N"	"P"
30"	38-3/4	2-1/8	31	73-3/4	54-3/4	28	1-1/4	20	1"	39-1/2	1-11/16	24	27	14-7/8
36"	46	2-3/8	34-3/4	83-7/16	58-7/8	32	1-1/2	24	1"	46-1/2	2	27-1/4	30-1/4	14-7/8
42"	53	2-5/8	37-1/2	100-3/4	78	36	1-1/2	28	1-1/4	54	2	30-15/16	35-7/16	17
48"	59-1/2	2-3/4	39	103-3/4	78	44	1-1/2	32	1-1/4	60-3/4	2	33-15/16	38-7/16	17

2638-72
B 10/28/10

Complies with applicable
requirements of AWWA C515

30"-48" R/W VALVE SPUR GEAR
ASSEMBLY WITH BYPASS

CLOW VALVE COMPANY

MODEL 2638

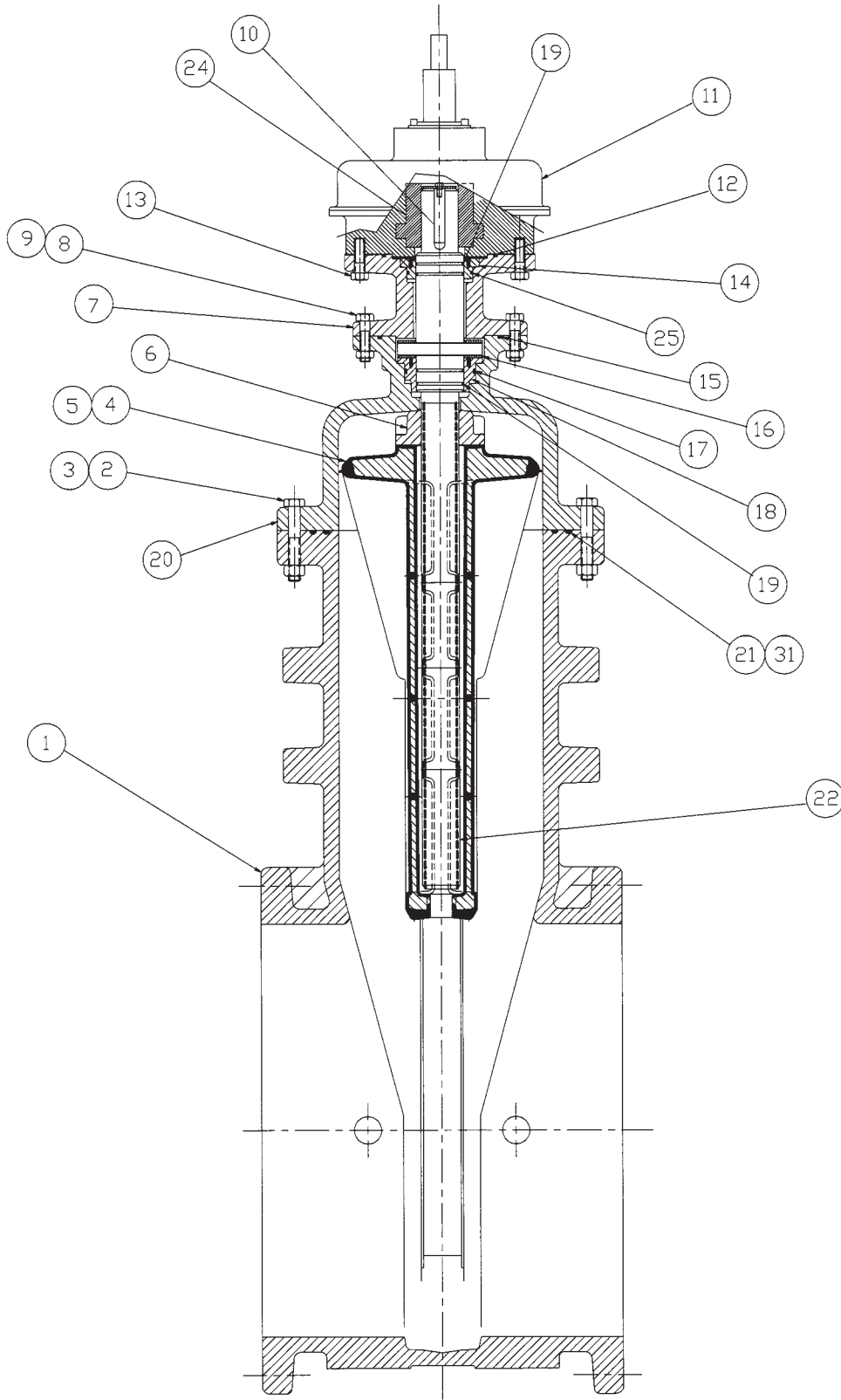

2638-73
C 10/10

Complies with applicable
requirements of AWWA C515

30"-48" R/W VALVE SPUR GEAR
ASSEMBLY WITH BYPASS

CLOW VALVE COMPANY

MODEL 2638

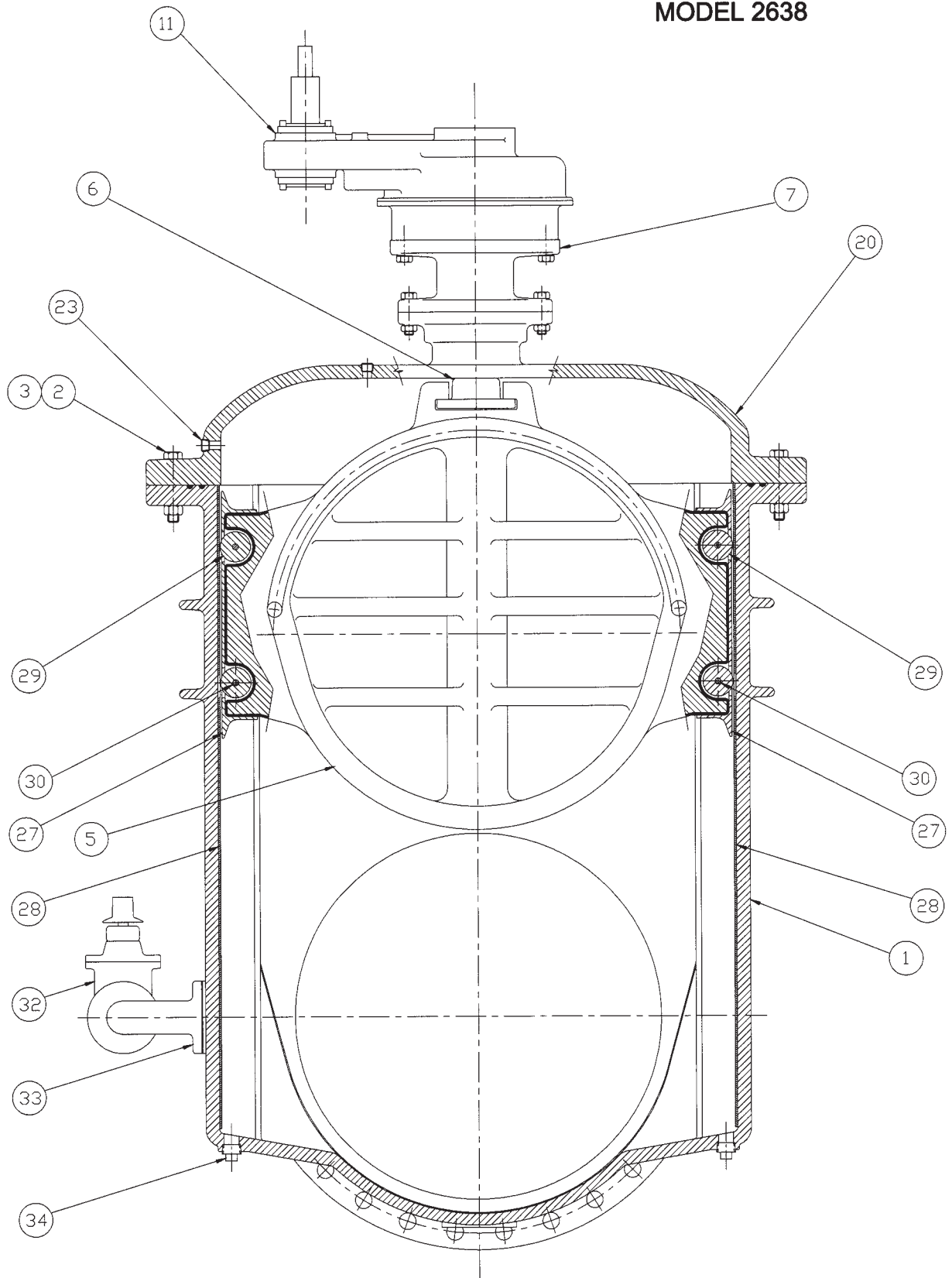

Complies with applicable
requirements of AWWA C515

30"-48" R/W VALVE SPUR GEAR
PARTS LIST WITH BYPASS

CLOW VALVE COMPANY

MODEL 2638

Item	Description	Material
1	Body - Mechanical Joint	Ductile iron
	Body - Flange	Ductile iron
	Body - MJ x Flange	Ductile iron
2	Bolt	Stainless Steel
3	Nut	Stainless Steel
4	Wedge Casting	Ductile iron
5	Molded Wedge	Rubber
6	Stem Nut	Copper Alloy
7	Extension - actuator	Ductile iron
8	Bolt	Stainless Steel
9	Nut	Stainless Steel
10	Key	Steel
11	Actuator - spur gear	-
12	O-ring	Rubber
13	Bolt	Stainless Steel
14	Bushing - stem guide	Copper Alloy
15	O-ring	Rubber
16	Thrust Bearing	Nylatron
17	O-ring	Rubber
18	Cover Bushing	Copper Alloy
19	O-ring	Rubber
20	Cover	Ductile iron
21	O-ring - cover outer	Rubber
22	Stem	Copper Alloy
23	Pipe Plug	Stainless Steel
24	Actuator Drive Bushing	Steel
25	O-ring	Rubber
27	Scraper	Copper Alloy
28	Track	Stainless Steel
29	Roller	Copper Alloy
30	Pin - roller	Stainless Steel
31	O-ring - cover inner	Rubber
32	Bypass Valve	Ductile iron
33	Bypass Elbow	Ductile iron
34	Pipe Plug	Stainless Steel

2638-75
C 10/10

Complies with applicable requirements of AWWA C515

30"-48" R/W VALVE FLANGED ENDS SPUR GEAR BYPASS GENERAL DIMENSIONS

CLOW VALVE COMPANY

MODEL 2638

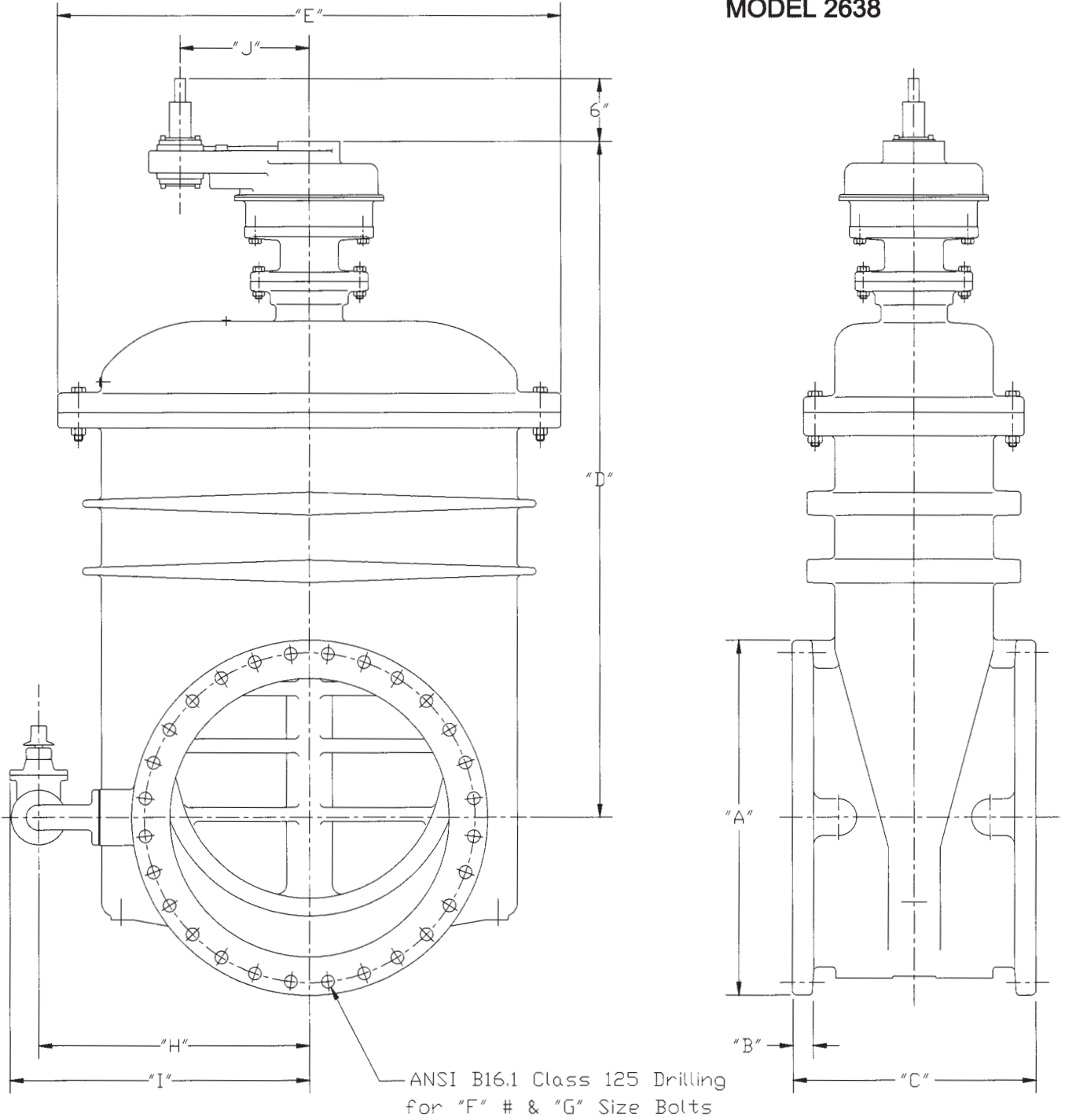

Valve Size	"A"	"B"	"C"	"D"	"E"	"F"	"G"	"H"	"I"	"J"
30"	38-3/4	2-1/8	26-1/2	74	54-3/4	28	1-1/4	29-7/16	32-7/16	14
36"	46	2-3/8	30-3/4	83-11/16	58-7/8	32	1-1/2	32-7/8	35-7/8	14
42"	53	2-5/8	36	102-1/2	78	36	1-1/2	42-9/16	47-1/16	16
48"	59-1/2	2-3/4	35-1/2	105-1/2	78	44	1-1/2	42-9/16	47-1/16	16

2638-134
- 04/13

Complies with applicable requirements of AWWA C515

30"-48" R/W VALVE MJ x FLG ENDS SPUR GEAR BYPASS GENERAL DIMENSIONS

CLOW VALVE COMPANY

MODEL 2638

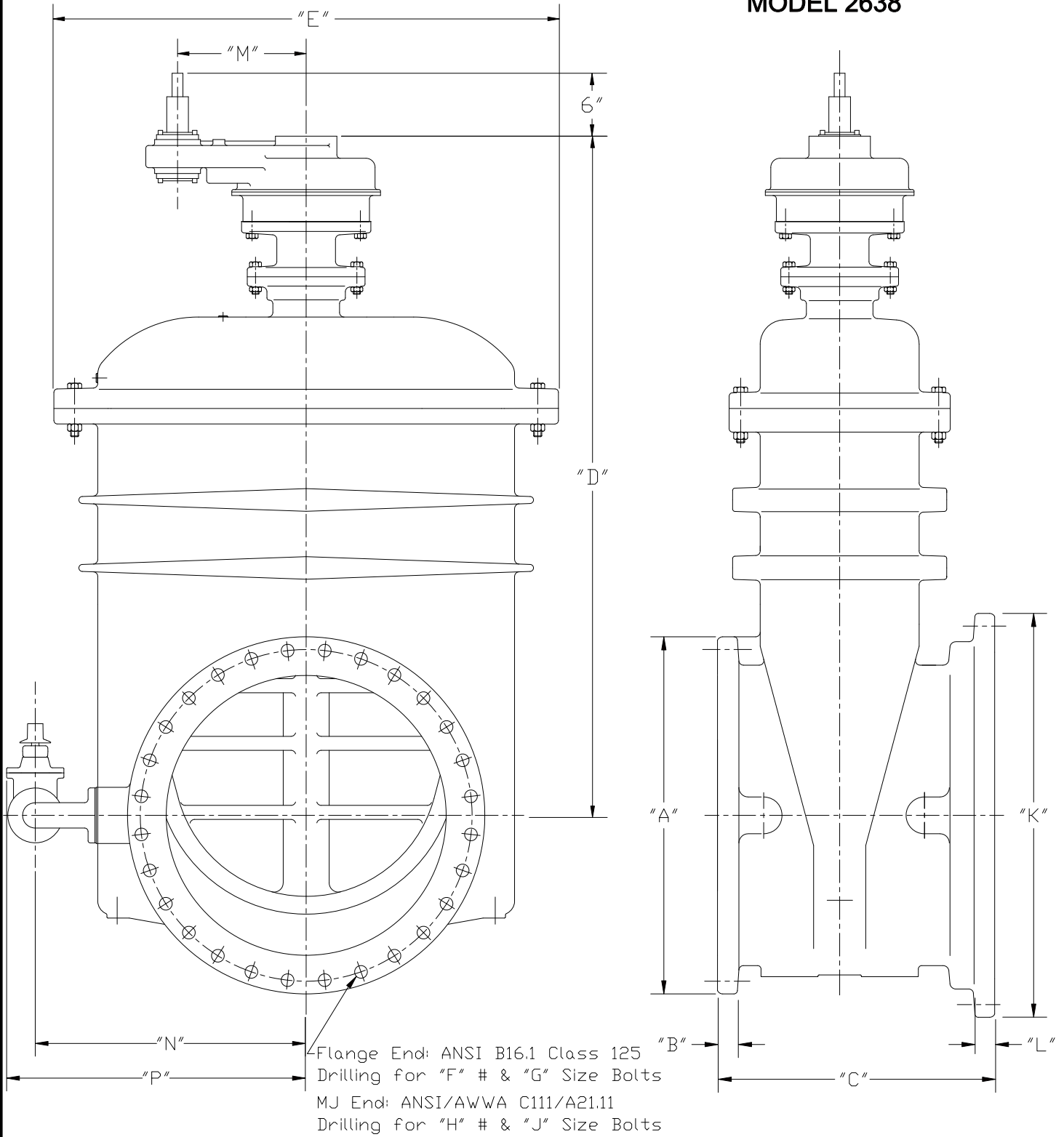

Valve Size	"A"	"B"	"C"	"D"	"E"	"F"	"G"	"H"	"J"	"K"	"L"	"M"	"N"	"P"
30"	38-3/4	2-1/8	31	74	54-3/4	28	1-1/4	20	1"	39-1/2	1-11/16	14	29-7/16	32-7/16
36"	46	2-3/8	34-3/4	83-11/16	58-7/8	32	1-1/2	24	1"	46-1/2	2	14	32-7/8	35-7/8
42"	53	2-5/8	37-1/2	102-1/2	78	36	1-1/2	28	1-1/4	54	2	16	42-9/16	47-1/16
48"	59-1/2	2-3/4	39	105-1/2	78	44	1-1/2	32	1-1/4	60-3/4	2	16	42-9/16	47-1/16

2638-133
- 04/13

Complies with applicable requirements of AWWA C515

30" - 48" R/W VALVE MECH. JOINT ENDS
SPUR GEAR BYPASS GENERAL DIMENSIONS

CLOW VALVE COMPANY

MODEL 2638

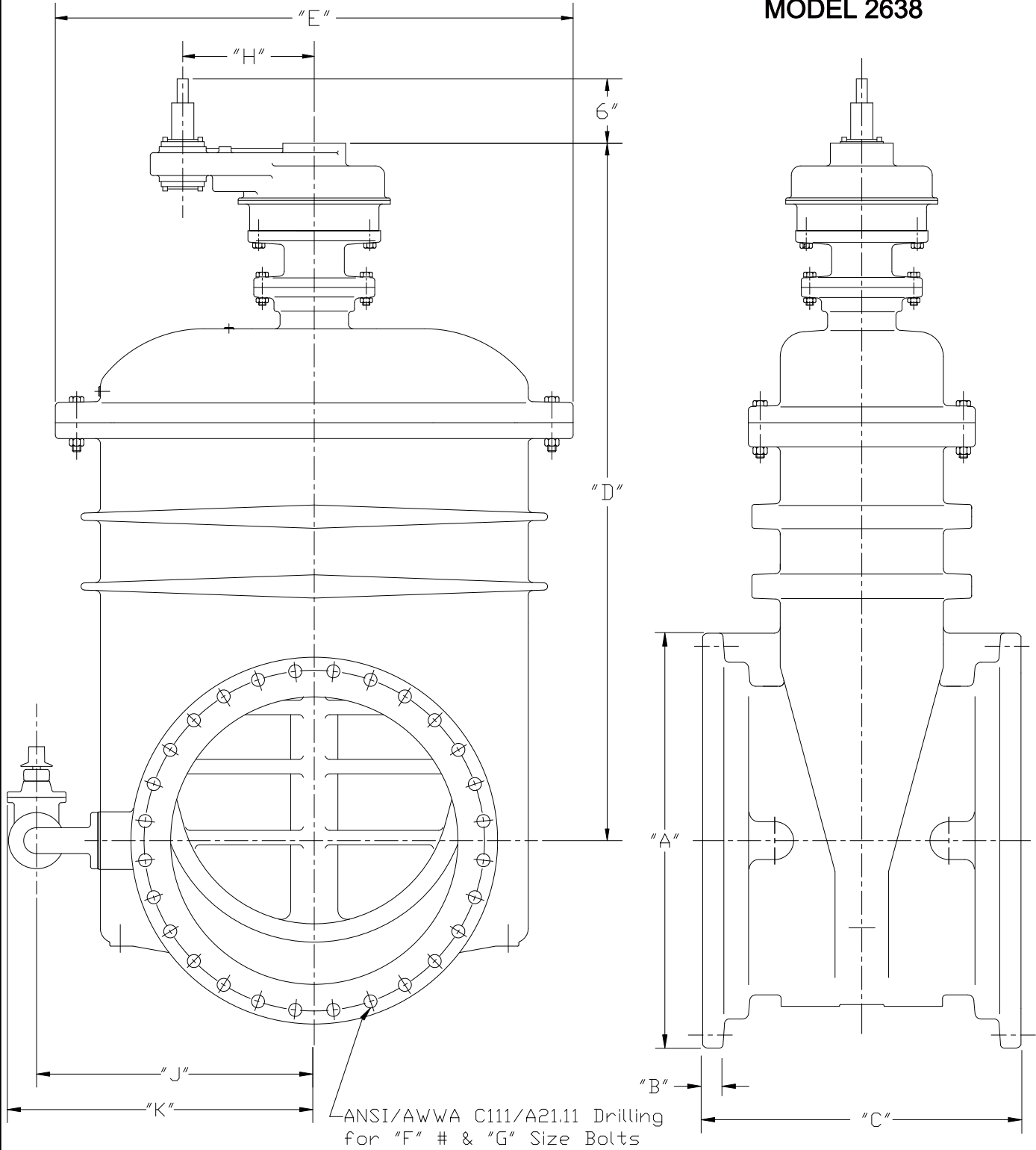

Valve Size	"A"	"B"	"C"	"D"	"E"	"F"	"G"	"H"	"J"	"K"
30"	39-1/2	1-11/16	35-1/2	74	54-3/4	20	1"	14	29-7/16	32-7/16
36"	46-1/2	2	38-3/4	83-11/16	58-7/8	24	1"	14	32-7/8	35-7/8
42"	54	2	39	102-1/2	78	28	1-1/4	16	42-9/16	47-1/16
48"	60-3/4	2	42	105-1/2	78	32	1-1/4	16	42-9/16	47-1/16

14"-48" R/W VALVE AWWA SERVICE
Performance Information

CLOW VALVE COMPANY

MODEL 2638

1. Valve complies with AWWA C515 specs where applicable.
2. Valve is rated at 250 psi working pressure.
3. Valve is bubble-tight at all pressures up to full rated pressure (250 psi).
4. Valve is capable of bubble-tight seal at twice the rate pressure (500 psi) for short periods of time.
5. Valve has been subjected to torques 150 percent of the designated minimum required torques.
6. Valve has been cycle tested 5,000 times without loss of bubble-tight seal.
7. Rubber to iron bond on wedge is inspected for strength as per ASTM D 429 specification.

NOTE:

It is recommended that valves be installed with stems vertical when used in raw sewage or sludge applications or in water with excessive sediment.

R/W RESILIENT WEDGE GATE VALVE
Product Analysis

CLOW VALVE COMPANY

MODEL 2638

Features	Benefits
Bubble Tight Closure at 250 psi (2"-48") (AWWA SERVICE)	<ul style="list-style-type: none"> No leakage—no loss of water
Smooth, Unobstructed Waterway	<ul style="list-style-type: none"> High flow characteristics 100% smooth passage without turbulent flow No sediment build-up Will not impede travel of line cleaning tools
Only Three Internal Parts	<ul style="list-style-type: none"> Virtually maintenance free
No Seat Rings	<ul style="list-style-type: none"> Nothing to be damaged by scoring
Delrin* Anti-Friction Thrust Bearing	<ul style="list-style-type: none"> Operating torque to close and open held to absolute minimum
Solid, Bronze Stem Nut and High Strength Bronze Stem	<ul style="list-style-type: none"> No corrosion Trouble-free service
Stem Nut is Self Centering	<ul style="list-style-type: none"> Eliminates possible stress on stem and wedge
Two "O" Ring Seals Above Stem Thrust Collar	<ul style="list-style-type: none"> Can be replaced with valve in service
High Strength Iron Wedge Fully Encapsulated with Rubber Permanently Bonded to Metal. Wedge Design Incorporates Two Seating Surfaces.	<ul style="list-style-type: none"> Trouble-free service with minimum maintenance No leaks—no wear

*DuPont Trademark

NOTE:

It is recommended that valves be installed with stems vertical when used in raw sewage or sludge applications or in water with excessive sediment.

RECOMMENDED SPECIFICATIONS FOR
C-515 RESILIENT WEDGE GATE VALVES

CLOW VALVE COMPANY

MODEL 2638

NOTE:

It is recommended that valves be installed with stems vertical when used in raw sewage or sludge applications or in water with excessive sediment.

Valves shall conform to the latest revision of AWWA Standard C-515 covering Resilient Wedge Gate Valves for Water Supply Service.

The valves shall have a ductile iron body, bonnet, and oring plate. The wedge shall be totally encapsulated with rubber.

The sealing rubber shall be permanently bonded to the wedge per ASTM D429.

Valves shall be supplied with oring seals at all pressure retaining joints. No flat gaskets shall be allowed.

The valves shall be either non-rising or rising stem, opening by turning left or right, and provided with 2" square operating nut or a handwheel with the word "Open" and an arrow to indicate the direction to open.

Stems for NRS assemblies shall be cast bronze with integral collars in full compliance with AWWA. OS&Y(rising stems) shall be of bronze. All stems shall operate with bronze stem nuts independent of wedge and of stem (in NRS valves). Stainless steel stems or stem nuts are not allowed. NRS stems shall have two orings located above thrust collar and one oring below. Stem orings shall be replaceable with valve fully open and subjected to full pressure. The NRS stems on 4"-12" shall also have two low torque thrust bearings located above and below the stem collar to reduce friction during operation.

Waterway shall be smooth, unobstructed and free of all pockets, cavities and depressions in the seat area. Valves 4" and larger shall accept a full size tapping cutter.

The body, bonnet, and oring plate shall be epoxy coated, both interior and exterior on body and bonnet. Epoxy shall be applied in accordance with AWWA C-550 and be NSF 61 certified.

Each valve shall have maker's name, pressure rating, and year in which it was manufactured cast in the body. Prior to shipment from the factory, each valve shall be tested by hydrostatic pressure equal to the requirements of AWWA C-515 (and ULFM where applicable).

Valves shall have all component parts cast and assembled in the USA and shall be manufactured by the Clow Valve Company.